

# IOT Relay User Manual

## V1.9.6

1 Product Overview.....	3
1.1 Overview.....	3
1.2 Technical Parameters.....	4
2 Image and Size.....	5
3 Interface Description.....	6
3.1 LED.....	6
3.2 Relay Contact.....	6
3.3 Reset To Factory.....	7
3.4 External input/Button control.....	8
3.5 Add Spark killer and contractor.....	9
4 Ethernet Web Page.....	10
4.1 Login.....	11
4.2 Setting Network.....	11
4.3 Relay Connect.....	12
4.4 Relay CGI Test.....	15
4.5 Relay Task.....	15
4.6 Input.....	16
4.7 Input Link Relay.....	17
4.8 IP WatchDog.....	17
4.9 Reset User.....	18
4.10 To Factory.....	18
4.11 Reboot.....	19
5 WIFI web Page.....	20
5.1 Login.....	20
5.2 Setting WIFI.....	20
5.3 Setting Relay Connect.....	21
5.4 Relay CGI Test.....	23
5.5 Relay Task.....	24
5.6 Input.....	25
5.7 Input Link Relay.....	25
5.8 IP WatchDog.....	26
5.9 Reset User.....	27
5.10 To Factory.....	27
6 IP Finder.....	28
6.1 Search Device.....	29
6.2 Change Static IP.....	30
Appendix I How to Test Command.....	31
step 1: download SDK.....	31

step 2: Change NetAssist language.....	32
step 3: Control relay via NetAssist network tool by wifi module.....	33
step 4: open UDP listen.....	35
step 5: control relay via wifi module.....	36
Appendix II How to use Domoticz.....	37
step 1: install Dingtian plugin to Domoticz.....	37
1 Stop Domoticz.....	37
2 Copy Domoticz_plugins\dingtian to Domoticz plugin dir.....	37
step 2: config Dingtian Relay board.....	38
Domoticz Ethernet.....	38
Domoticz WIFI.....	39
step 3: Add Dingtian Relay to Domoticz.....	40
1 Install Python 3.8.2.....	40
2 Run to Domoticz.....	40
3 Add Dingtian Relay to Domoticz.....	41
4 Control Dingtian Relay with Domoticz.....	46
step 4: Domoticz mobile application.....	48
1 Set the Location, User name and password on PC Domoticz.....	48
2 Install Domoticz.....	48
3 Set Domoticz Server parameter.....	49
Appendix III How to MQTT.....	50
step 1: Install and config Broker.....	55
step 2: Install MQTT PC client.....	55
step 3: MQTTBox Add Client.....	55
step 4: MQTTBox Publish topic to relay board and subscribe topic.....	57
Appendix IV How to CoAP.....	58
step 1: compile libcoap.....	58
step 2: CoAP Get relay status.....	58
step 3: CoAP Control relay(simple).....	58
step 4: CoAP Control relay.....	59
Appendix V How to “input mutual control”.....	61
Appendix VI How to Home Assistant.....	63
Step 1 config Relay board.....	63
Step 2 Install MQTT Broker.....	64
Step 3 Install Home Assistant.....	64
1 install python.....	64
2 install Home Assistant.....	64
3 Add relay board Switch and input to Home Assistant.....	64
4 Home Assistant config MQTT Broker.....	66

# 1 Product Overview

## 1.1 Overview

Support multiple channel relay, On/OFF/Jogging/Delay.

Support multiple interface RJ45/RS485/CAN/WIFI

Support HTTP GET CGI/UDP/TCP Server/TCP Client

10/100Mbps ethernet, Auto-MDIX,DHCP ip,Static IP

Local Button control(SelfLock/Jogging/Delay)

WEB config and control

Support password.

Support Modbus-RTU/ASCII/TCP/UDP/WIFI

Support Modbus-RTU Over TCP/UDP/WIFI

Support Modbus-ASCII Over TCP/UDP/WIFI

Support MQTT(Ethernet and WIFI)

Support CoAP

Support Domoticz

Support Home Assistant

Home Automation System Support:

Name	How to
Domoticz	<a href="#">Appendix II How to use Domoticz</a> <a href="https://github.com/dtlzp/Domoticz-Dingtian-Relay-Plugin">https://github.com/dtlzp/Domoticz-Dingtian-Relay-Plugin</a> (Software version <=V2.16.xx, please use V1.1 for github; software version V2.17.xx or more, please use V1.2 for github)
Home Assistant	Appendix VI How to Home Assistant

Noted: when using Domoticz, please close your firewall or let your firewall allow the domoticz server port

SDK download link:

[http://www.dingtian-tech.com/sdk/relay\\_sdk.zip](http://www.dingtian-tech.com/sdk/relay_sdk.zip)

## 1.2 Technical Parameters

Network	Interface	RJ45/ RS485/CAN/WIFI
	Baudrate	100M/115200bps/125kbps/150Mbps
	Protocol	TCP server/client, UDP HTTP GET CGI, Modbus-RTU/ASCII/TCP/UDP/WIFI Modbus-RTU Over TCP/UDP/WIFI Modbus-ASCII Over TCP/UDP/WIFI MQTT(Ethernet and WIFI) CoAP
Output	Relay Power	AC 250V/10A,DC 30V/10A
	Contacts	Normally Close(NC) Normally Open(NO)
	Delay	1~65535 seconds
	Momentary	Pull in 0.5 seconds, automatically release
Working environment	Operating temperature	0~+85°C
Power	Power Specifications	12/24VDC 12/24VAC
	Current	2 channel: 0.15A/12V(recommend 1A/12V) 4 channel: 0.25A/12V(recommend 1A/12V) 8 channel: 0.5A/12V(recommend 2A/12V)
	Power consumption	2 channel: 2W 4 channel: 3W 8 channel: 5W

## 2 Image and Size

Hole size: 3.5mm



# 3 Interface Description

## 3.1 LED

wifi led	on: Connect WIFI successfully off: Disconnect WIFI
CH1-CH8 led	on: relay on off: relay off

## 3.2 Relay Contact

Connect Example:

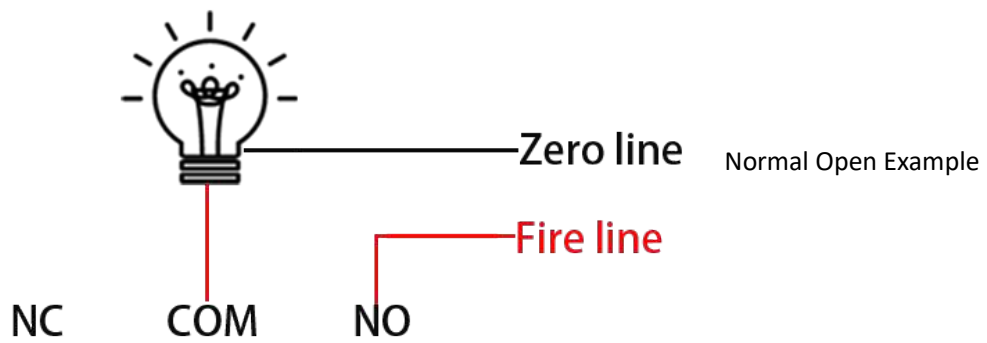
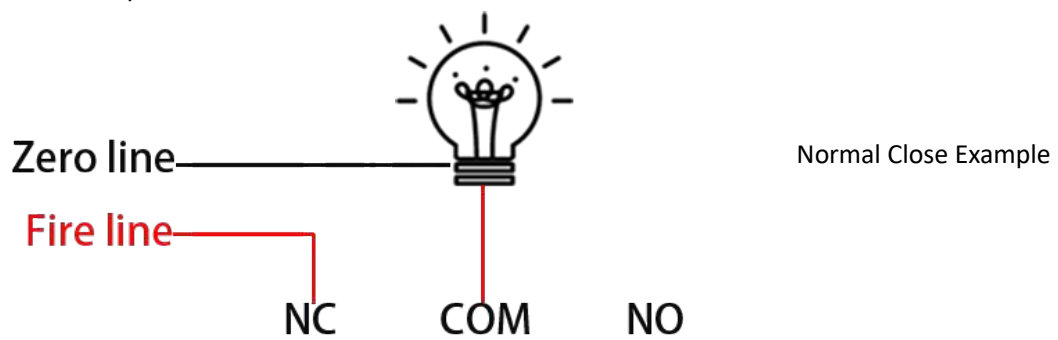

### 3.3 Reset To Factory

1. Short-circuit the 2 pin headers under the Default assembly with a jumper cap

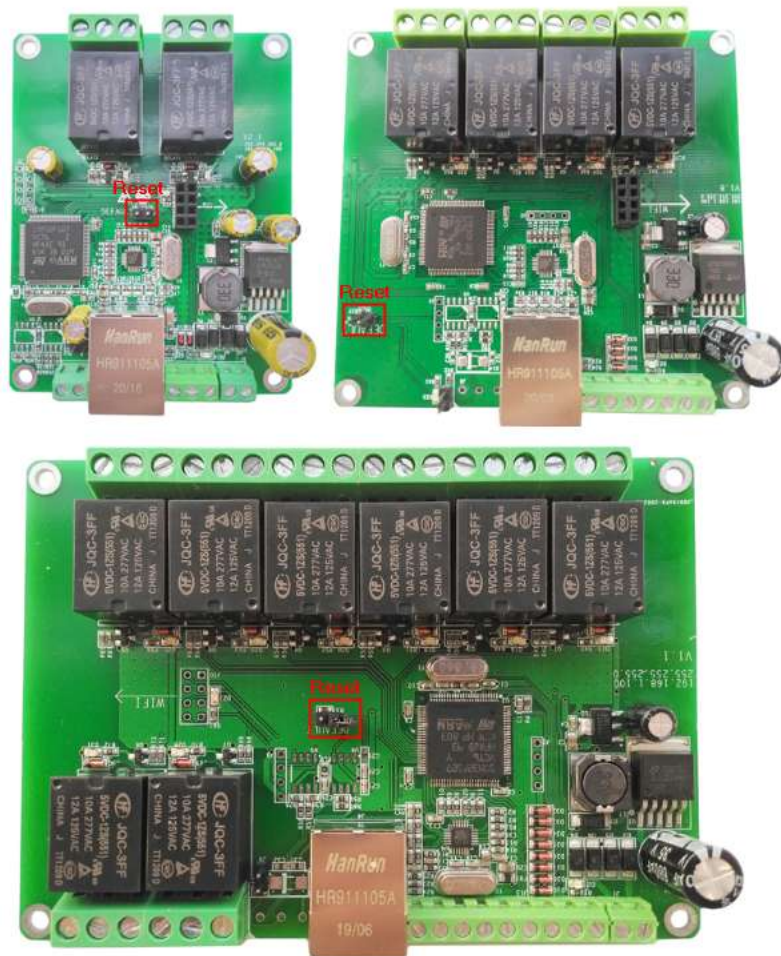

- 2 Power off the relay board
- 3 Power on the relay board
- 4 Pull out the Default jumper cap

### 3.4 External input/Button control

K0~K7 Control Relay1~8

0V Relay On

3.3V Relay Off (Hardware Version < V1.8)

3.3V/5V/12V/24V Relay Off (Hardware Version >= V1.8)

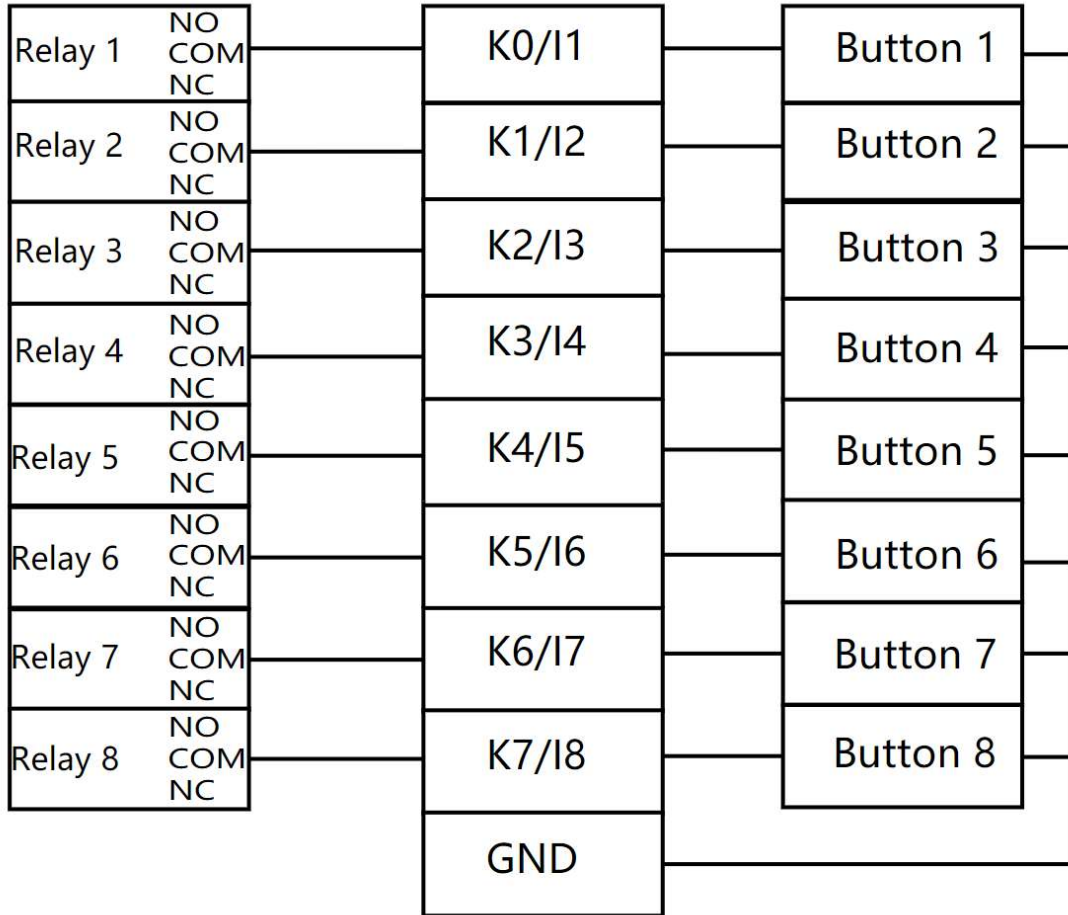



### 3.5 Add Spark killer and contractor

R1,C1 are used for relay on/off interference suppression, protection control circuit

R2,C2 are used to suppress the relay on/off spark

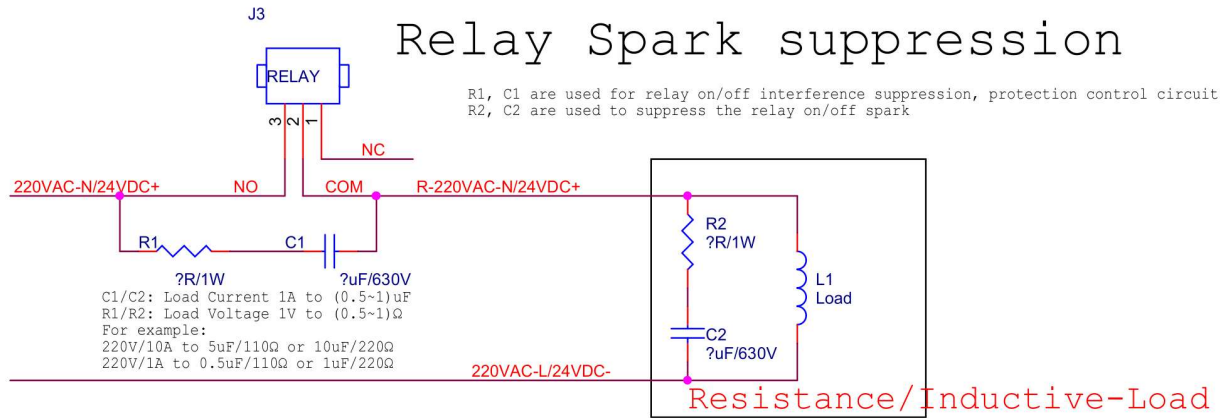

Our max current is 10A, if the current of your device is too big, suggest add a contractor

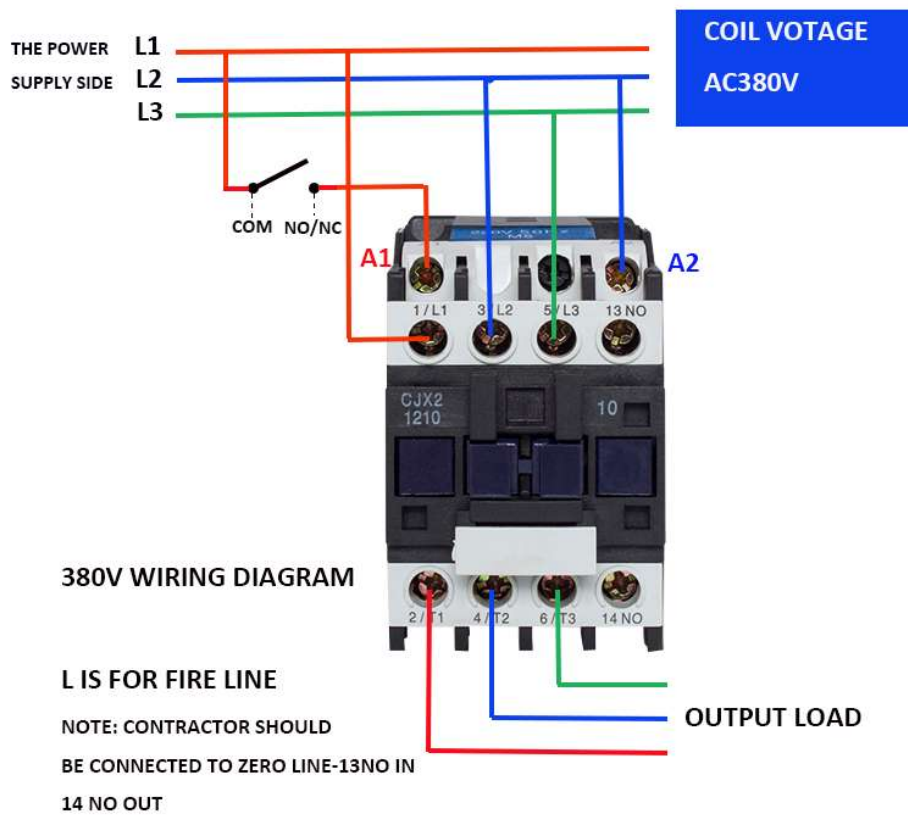

# 4 Ethernet Web Page

IE is not support, please use firefox and chrome



## 4.1 Login

Default IP: 192.168.1.100

user: admin

password: admin

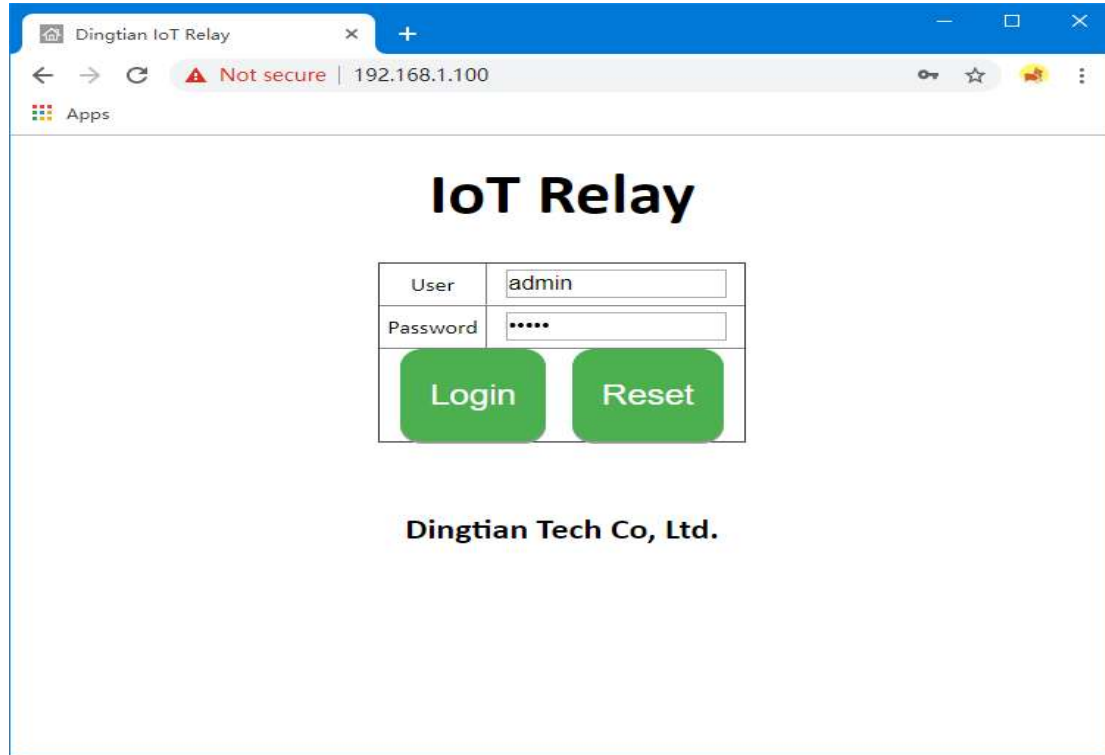

## 4.2 Setting Network

Set network information, NTP Server on Relay setting page  
after click "Save" button, device will reboot

**Parameter:**

**Software Version:** Relay board firmware version

**Model:**

2CH is Dingtian IOT RELAY-2

4CH is Dingtian IOT RELAY-4

8CH is Dingtian IOT RELAY-8

**Serial Number:** Relay board Serial Number

**Date Time:** current date and time (Need internet because of NTP)

**NTP Server:** NTP server get time from, suggest use pool.ntp.org

**DHCP:** Ethernet IP DHCP or Static

**IP:** Ethernet current IP Address

**Netmask:** Ethernet current Netmask

**Gateway:** Ethernet current Gateway

**DNS:** Ethernet current DNS Server

## MAC: Ethernet current MAC address

The screenshot shows a web browser window with two tabs: 'Dingtian IOT Relay' and 'Dingtian IOT WiFi Relay'. The address bar shows '192.168.1.100/menu\_page.html'. The main heading is 'Dingtian IOT Relay' and the page title is 'Setting'. A left sidebar menu contains options like 'Relay Connect', 'Relay CGI Test', 'Relay Task', 'Input', 'Input Link Relay', 'IP WatchDog', 'Reset User', 'To Factory', and 'Reboot'. The 'Setting' option is highlighted. The main content area displays a table of system parameters:

Hardware Version	V1.4
Software Version	V2.17.28
Build Date	2021-01-21 21:23:13
Model	Dingtian IOT RELAY-8
Serial Number	1868
Date Time	1/28/2021, 23:31:43
NTP Server	pool.ntp.org
Hostname	Dingtian-Relay1868
Hostname+Suffix	Dingtian-Relay + SN
HTTP Server Port	80
DHCP	No
IP	192.168.1.100
Netmask	255.255.255.0
Gateway	192.168.1.1
DNS	192.168.1.1
MAC	bc:34:88:00:06:9d
WiFi AP IP	192.168.7.1
WiFi STA IP	192.168.1.97

At the bottom of the table is a green 'Save' button.

## 4.3 Relay Connect

Set control interface parameter of relay board on the Relay connect page and test relay

After click "Save" button, device will reboot

Protocol refers to [programming manual\\_en.pdf](#)

### Channel Parameter:

**RS485:** RS485 protocol, addr, baudrate, databits, stopbits, parity config

Protocol:

Dingtian String

Dingtian Binary

Modbus-RTU

Modbus-ASCII

Baudrate:

1200bps,2400bps,4800bps,9600bps,19200bps,38400bps,57600bps,115200bps

**CAN:** CAN protocol, ID, Speed config

Protocol:

Dingtian String

Dingtian Binary

Modbus-RTU(0x03,0x06),only support Read/Write single register once time

Speed:

5Kbps,10Kbps,20Kbps,25Kbps,50Kbps,100Kbps,125Kbps,200Kbps,250Kbps,500Kbps,800Kbps,888Kbps,1Mbps

**ETH-UDP1:** Ethernet UDP1 protocol, Remote Server Address,Remote Server Port,Local Port config  
Protocol:

Dingtian String

Dingtian Binary

Modbus-RTU Over UDP

Modbus-ASCII Over UDP

Modbus-UDP

CoAP(need change port to 5683)

Input Mutual Control

**ETH-UDP2:** Ethernet UDP2 protocol, Remote Server Address,Remote Server Port,Local Port config  
Protocol:

Dingtian String

Dingtian Binary

Modbus-RTU Over UDP(use RS485 addr)

Modbus-ASCII Over UDP(use RS485 addr)

Modbus-UDP

CoAP(we suggest enable CoAP at ETH/WiFi-UDP2)

Input Mutual Control

**ETH-TCP Server:** Ethernet TCP Server protocol, Local Port config

Protocol:

Dingtian String

Dingtian Binary

Modbus-RTU Over TCP(use RS485 addr)

Modbus-ASCII Over TCP(use RS485 addr)

Modbus-TCP

**ETH-TCP Client:** Ethernet TCP Client protocol, Remote Server Address,Remote Server Port config

Protocol:

Dingtian String

Dingtian Binary

Modbus-RTU Over TCP(use RS485 addr)

Modbus-ASCII Over TCP(use RS485 addr)

Modbus-TCP

**ETH-MQTT:** Ethernet MQTT protocol, Broker Address, Broker Port, Broker Username, Broker Password config

Protocol:

MQTT(without tls)

**Other Parameter:**

**Relay Password:** use for checking control is valid, only correct password control relay board

**Keep Alive Second:** send relay status to server with every “Keep Alive Second”, **only protocol Dingtian String and Dingtian binary have Keep Alive Second**

**Jogging Time:** Jogging time, default is 500ms,1=100ms

what is Jogging: ON then delay 500ms OFF,or OFF then delay 500ms ON,

**Power Failure Recovery Relay:** relay status will restore after re-power

**Input Control Relay:** Input link relay output

**Button Type Parameter:**

**Selflock:** Connect **Selflock Button**,

press button relay ON,release button relay OFF

**Jogging:** Connect **Momentary Button**,

press and release button relay Jogging(ON and delay 500ms OFF)

**Momentary:** Connect **Momentary Button**,

press and release button relay ON,press and release button relay OFF

How to Connect button please move to 3.4 External input/Button control

**Relay**

Channel	Protocol	Addr	Baud	Databits	Stopbits	Parity
RS485	Modbus-RTU	ID	115200bps	8bit	1bit	None
CAN	Dingtian String	ID	Speed			
ETH-UDP1	Dingtian Binary	Remote Address	125Kbps	Remote Port	Local Port	
ETH-UDP2	Dingtian String	Remote Address		Remote Port	Local Port	
ETH-TCP Server	Modbus-TCP			Remote Port	Local Port	
ETH-TCP Client	Modbus-RTU Over TCP	Remote Address		Remote Port		
ETH-MQTT	MQTT	Broker Address		Broker Port	Broker Username	Broker Password

**Other**

Relay Password	0	0-9999(0 no password)
Keep Alive Second	30	1-120 second(0 close)
Jogging Time	5	1-255 (1=100ms)
Power Failure Recovery Relay	No	
Input Control Relay	Yes	

**Button Type**

Momentary	Momentary	Momentary	Momentary
Momentary	Momentary	Momentary	Momentary

**Save**

**Relay Test**

Relay1:On   Relay2:On   Relay3:On   Relay4:On

Relay5:On   Relay6:On   Relay7:On   Relay8:On

## 4.4 Relay CGI Test

relay CGI test

**Relay CGI Test**

Relay Password: 0 (0~9999)

Relay	Status	Jogging(1~255 100ms)	Delay(1~65535 Second)	On/Off	Jogging	Delay	
1	On	On   5   500ms	On   5   second		Do Off	Do Jogging	Do Delay
2	On	On   5   500ms	On   5   second		Do Off	Do Jogging	Do Delay
3	On	On   5   500ms	On   5   second		Do Off	Do Jogging	Do Delay
4	On	On   5   500ms	On   5   second		Do Off	Do Jogging	Do Delay
5	On	On   5   500ms	On   5   second		Do Off	Do Jogging	Do Delay
6	On	On   5   500ms	On   5   second		Do Off	Do Jogging	Do Delay
7	On	On   5   500ms	On   5   second		Do Off	Do Jogging	Do Delay
8	On	On   5   500ms	On   5   second		Do Off	Do Jogging	Do Delay

Relay CGI load success!

## 4.5 Relay Task

Choose "Repeat", you can ask repeat by second/minute/hour/day/week/month

**Relay Task**

Relay task begin time

Task	Enable	Relay Mode	On/Off	Delay/Jogging	Repeat	Week	Month	Day	Hour	Minute	Second	Interval	
1	Yes	1	On/Off	On	0	No	SUN MON TUE WED THU FRI SAT	2	6	17	32	31	0
2	No	1	On/Off	On	0	No	SUN MON TUE WED THU FRI SAT	1	1	0	0	0	0
3	No	1	On/Off	On	0	No	SUN MON TUE WED THU FRI SAT	1	1	0	0	0	0
4	No	1	On/Off	On	0	No	SUN MON TUE WED THU FRI SAT	1	1	0	0	0	0
5	No	1	On/Off	On	0	No	SUN MON TUE WED THU FRI SAT	1	1	0	0	0	0





## 4.7 Input Link Relay

Select R1~R8, means you add the relay to link with Input, Click the green button R1~R8 means delete relay

**Dingtian IOT Relay**

Menu

- Setting
- Relay Connect
- Relay CGI Test
- Relay Task
- Input
- Input Link Relay**
- IP WatchDog
- Reset User
- To Factory
- Reboot

**Input Link Relay**

	Input ON (Action ON)	ON (Action OFF)	OFF (Action ON)	OFF (Action OFF)				
I1	R1	R1	R1	R1	R1	R1	R1	R1
I2	R1	R2	R1	R1	R1	R1	R1	R2
I3	R1	R3	R1	R1	R1	R1	R1	R3
I4	R1	R4	R1	R1	R1	R1	R1	R4
I5	R1	R5	R1	R1	R1	R1	R1	R5
I6	R1	R6	R1	R1	R1	R1	R1	R6
I7	R1	R7	R1	R1	R1	R1	R1	R7
I8	R1	R8	R1	R1	R1	R1	R1	R8

How to: Select Add/Click Delete

**Save**

load success!

## 4.8 IP WatchDog

When Enable IP WatchDog function, all relay ON, when the "Watch IP" offline, relay OFF, after seconds, the relay ON automatically, "Ping Interval" must be bigger than "Ping Timeout"

**Dingtian IOT Relay**

Menu

- Setting
- Relay Connect
- Relay CGI Test
- Relay Task
- Input
- Input Link Relay
- IP WatchDog**
- Reset User
- To Factory
- Reboot

**IP WatchDog**

Enable IP WatchDog

WatchDog	Enable	Off Relay	Watch IP	Relay Off	Ping Interval	Ping Timeout	Ping Retry	Times Offline	Action Time			
1 offline	Yes	R1	R1	8.8.8.8	10	S	2	S	1	S	60	00:02:00
2 offline	Yes	R1	R1	192.168.1.1	10	S	2	S	1	S	30	00:01:00
3 offline	Yes	R1	R2	192.168.1.2	10	S	2	S	1	S	30	00:01:00
4 offline	Yes	R1	R3	192.168.1.3	10	S	2	S	1	S	30	00:01:00
5 offline	Yes	R1	R4	192.168.1.4	10	S	2	S	1	S	30	00:01:00
6 offline	Yes	R1	R5	192.168.1.5	10	S	2	S	1	S	30	00:01:00
7 offline	Yes	R1	R6	192.168.1.6	10	S	2	S	1	S	30	00:01:00
8 offline	Yes	R1	R7	192.168.1.7	10	S	2	S	1	S	30	00:01:00
9 offline	Yes	R1	R8	192.168.1.8	10	S	2	S	1	S	30	00:01:00

Off Relay: Select Add/Click Delete  
"Ping Interval" Must Greater than "Ping Timeout"

**Save**

load success!

## 4.9 Reset User

The screenshot shows a web browser window with two tabs: 'Dingtian IOT Relay' and 'Dingtian IOT WiFi Relay'. The address bar shows 'Not secure | 192.168.1.100'. The page title is 'Dingtian IOT Relay'. On the left, a 'Menu' sidebar lists various options, with 'Reset User' highlighted in a red box. The main content area features the heading 'Reset User' and a form with the following fields:

Old User	admin
Old password	
New User	
New password	

Below the form is a green 'Reset' button.

## 4.10 To Factory

The screenshot shows the same web browser window as in the previous image. The page title is 'Dingtian IOT Relay'. In the 'Menu' sidebar, 'To Factory' is highlighted in a red box. The main content area features the heading 'Factory' and a green 'To Factory' button.

## 4.11 Reboot

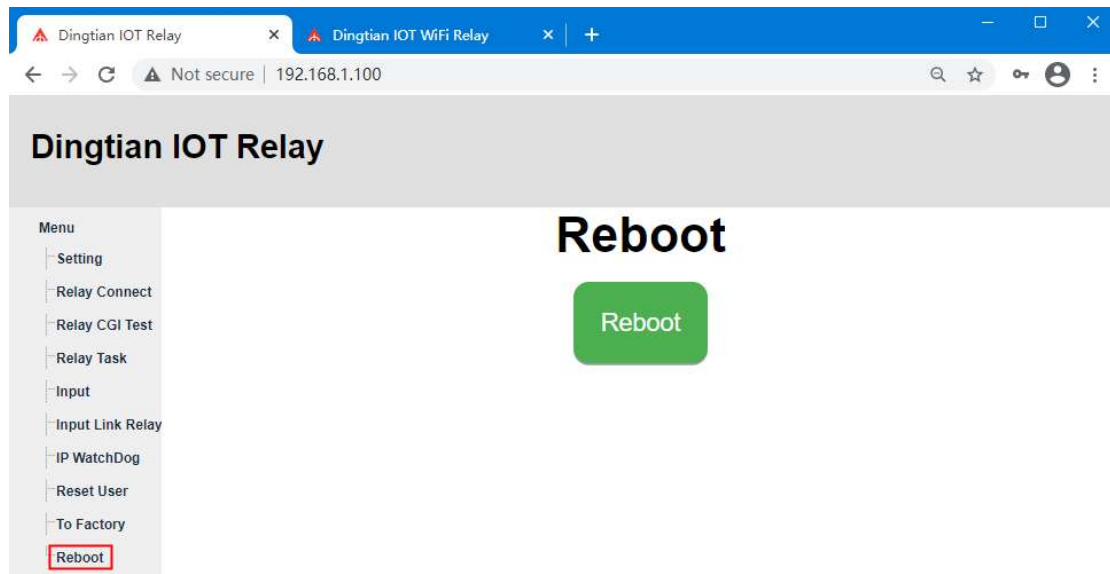

# 5 WIFI web Page

IE is not support, please use firefox and chrome

## 5.1 Login

Default IP: 192.168.7.1

user:admin

password:admin

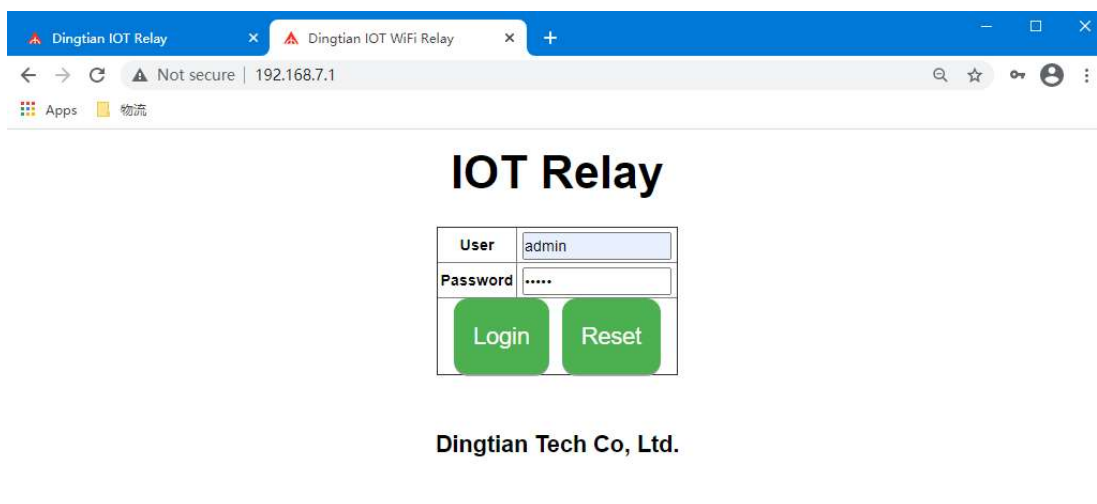

## 5.2 Setting WIFI

Set WIFI information, NTP Server and STA WIFI SSID and password on WIFI Relay setting page

After click "Save" button, device will reboot

**Parameter:**

**Software Version:** Relay board firmware version

**Model:**

2CH is Dingtian IOT WRELAY-2

4CH is Dingtian IOT WRELAY-4

8CH is Dingtian IOT WRELAY-8

**Serial Number:** Relay board Serial Number

**Date Time:** current date and time(Need internet because of NTP)

**NTP Server:** NTP server get time from, suggest use pool.ntp.org

**STA WiFi SSID:** Your Router WiFi Name, Relay board will access to your router

**STA WiFi Password:** Your Router WiFi Password, Relay board will access to your router

**STA IP:** Relay board get IP from your Router

**Netmask:** WIFI Netmask

**Gateway:** WIFI Gateway

**DNS:** WIFI DNS Server

**MAC:** WIFI MAC address

**AP IP:** WIFI default address

**AP SSID:** WIFI default name, as a router, we need to connect the WIFI with your computer firstly and access the wifi web

**AP Password:** WIFI default Password

we can use STA IP or AP IP to control relay board via WIFI, only accept to use one browser(Firefox or Chrome) to access.

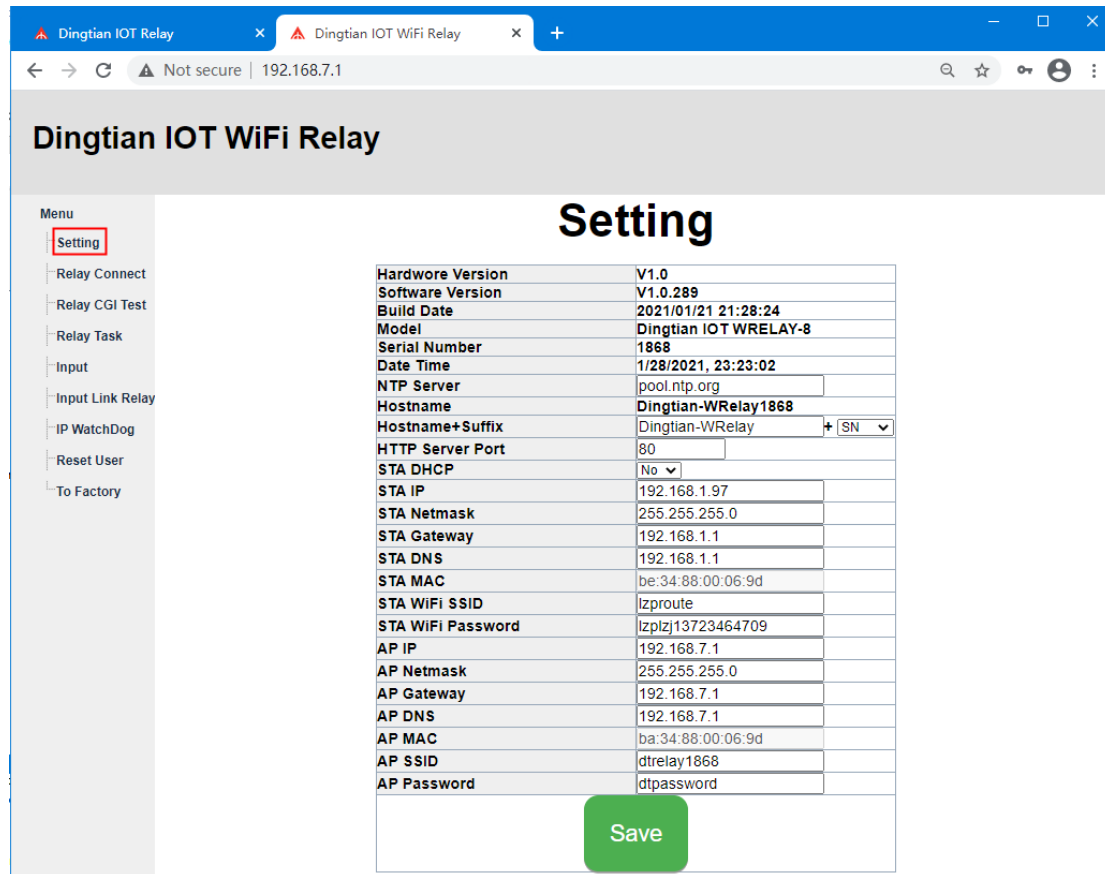

## 5.3 Setting Relay Connect

**WIFI-UDP1:** WIFI UDP1 protocol, Remote Server Address,Remote Server Port,Local Port config Protocol:

Dingtian String

Dingtian Binary

Modbus-RTU Over UDP(use RS485 addr)

Modbus-ASCII Over UDP(use RS485 addr)

Modbus-UDP

CoAP(need change port to 5683)

Input Mutual Control

**WIFI-UDP2:** WIFI UDP2 protocol, Remote Server Address,Remote Server Port,Local Port config Protocol:

Dingtian String

Dingtian Binary

Modbus-RTU Over UDP(use RS485 addr)

Modbus-ASCII Over UDP(use RS485 addr)

Modbus-UDP

CoAP(**we suggest enable CoAP at ETH/WiFi-UDP2**)

Input Mutual Control

**WIFI-TCP Server:** WIFI TCP Server protocol, Local Port config

Protocol:

Dingtian String

Dingtian Binary

Modbus-RTU Over TCP(use RS485 addr)

Modbus-ASCII Over TCP(use RS485 addr)

Modbus-TCP

**WIFI-TCP Client:** WIFI TCP Client protocol, Remote Server Address,Remote Server Port config

Protocol:

Dingtian String

Dingtian Binary

Modbus-RTU Over TCP(use RS485 addr)

Modbus-ASCII Over TCP(use RS485 addr)

Modbus-TCP

**WIFI-MQTT:** WIFI MQTT protocol, Broker Address, Broker Port, Broker Username, Broker Password config

Protocol:

**MQTT(without tls)**

**Other Parameter:**

**Relay Password:** use for checking control is valid, only correct password control relay board

**Keep Alive Second:** send relay status to server with every "Keep Alive Second", **only protocol Dingtian String and Dingtian binary have Keep Alive Second**

**Jogging Time:** Jogging time, default is 500ms,1=100ms

what is Jogging: ON then delay 500ms OFF,or OFF then delay 500ms ON

# Dingtian IOT WiFi Relay

- Menu
- Setting
- Relay Connect**
- Relay CGI Test
- Relay Task
- Input
- Input Link Relay
- IP WatchDog
- Reset User
- To Factory

## Relay

Channel	Protocol	Remote Address	Remote Port	Local Port	
WIFI-UDP1	Dingtian Binary	192.168.1.9	60000	60000	
WIFI-UDP2	Dingtian String	192.168.1.9	60001	60001	
WIFI-TCP Server	Modbus-TCP			Local Port	
				502	
WIFI-TCP Client	Modbus-RTU Over TCP	Remote Address	Remote Port		
			502		
WIFI-MQTT	MQTT	Broker Address	Broker Port	Broker Username	Broker Password
			1883	mqtt	123

Other		
Relay Password	0	0~9999(0 no password)
Keep Alive Second	30	1~120 second(0 close)
Jogging Time	5	1~255 (1=100ms)

Save

### Relay Test

Relay1:Off   Relay2:Off   Relay3:Off   Relay4:Off

Relay5:Off   Relay6:Off   Relay7:Off   Relay8:Off

## 5.4 Relay CGI Test

Dingtian IOT WiFi Relay

Menu

- Setting
- Relay Connect
- Relay CGI Test**
- Relay Task
- Input
- Input Link Relay
- IP WatchDog
- Reset User
- To Factory

### Relay CGI Test

Relay Password  (0~9999)

Relay	Status	Jogging(1~255 100ms)	Delay(1~65535 Second)	On/Off	Jogging	Delay
1	Off	<input type="text" value="5"/> 500ms	<input type="text" value="5"/> second	Do On	Do Jogging	Do Delay
2	Off	<input type="text" value="5"/> 500ms	<input type="text" value="5"/> second	Do On	Do Jogging	Do Delay
3	Off	<input type="text" value="5"/> 500ms	<input type="text" value="5"/> second	Do On	Do Jogging	Do Delay
4	Off	<input type="text" value="5"/> 500ms	<input type="text" value="5"/> second	Do On	Do Jogging	Do Delay
5	Off	<input type="text" value="5"/> 500ms	<input type="text" value="5"/> second	Do On	Do Jogging	Do Delay
6	Off	<input type="text" value="5"/> 500ms	<input type="text" value="5"/> second	Do On	Do Jogging	Do Delay
7	Off	<input type="text" value="5"/> 500ms	<input type="text" value="5"/> second	Do On	Do Jogging	Do Delay
8	Off	<input type="text" value="5"/> 500ms	<input type="text" value="5"/> second	Do On	Do Jogging	Do Delay

Relay CGI load success!





## 5.7 Input Link Relay

Select R1~R8, means you add the relay to link with Input, Click the green button R1~R8 means delete relay

**Dingtian IOT WiFi Relay**

Menu

- Setting
- Relay Connect
- Relay CGI Test
- Relay Task
- Input
  - Input Link Relay**
  - IP WatchDog
  - Reset User
  - To Factory

**Input Link Relay**

	Input ON (Action ON)	ON (Action OFF)	OFF (Action ON)	OFF (Action OFF)	
11	R1	R1	R1	R1	R1
12	R1	R2	R1	R1	R2
13	R1	R3	R1	R1	R3
14	R1	R4	R1	R1	R4
15	R1	R5	R1	R1	R5
16	R1	R6	R1	R1	R6
17	R1	R7	R1	R1	R7
18	R1	R8	R1	R1	R8

How to: Select Add/Click Delete

**Save**

load success!

## 5.8 IP WatchDog

When Enable IP WatchDog function, all relay ON, when the "Watch IP" offline, relay OFF, after seconds, the relay ON automatically, "Ping Interval" must be bigger than "Ping Timeout"

**Dingtian IOT WiFi Relay**

Menu

- Setting
- Relay Connect
- Relay CGI Test
- Relay Task
- Input
  - Input Link Relay
  - IP WatchDog**
  - Reset User
  - To Factory

**IP WatchDog**

Enable IP WatchDog

WatchDog	Enable	Off Relay	Watch IP	Relay	Off	Ping Interval	Ping Timeout	Ping Retry	Times	Offline Action	Time	
1 offline	Yes	R1	R1	8.8.8.8	10	S	2	S	1	S	60	00:02:00
2 offline	Yes	R1	R1	192.168.1.1	10	S	2	S	1	S	30	00:01:00
3 offline	Yes	R1	R2	192.168.1.2	10	S	2	S	1	S	30	00:01:00
4 offline	Yes	R1	R3	192.168.1.3	10	S	2	S	1	S	30	00:01:00
5 offline	Yes	R1	R4	192.168.1.4	10	S	2	S	1	S	30	00:01:00
6 offline	Yes	R1	R5	192.168.1.5	10	S	2	S	1	S	30	00:01:00
7 offline	Yes	R1	R6	192.168.1.6	10	S	2	S	1	S	30	00:01:00
8 offline	Yes	R1	R7	192.168.1.7	10	S	2	S	1	S	30	00:01:00
9 offline	Yes	R1	R8	192.168.1.8	10	S	2	S	1	S	30	00:01:00

Off Relay: Select Add/Click Delete  
"Ping Interval" Must Greater than "Ping Timeout"

**Save**

load success!

## 5.9 Reset User

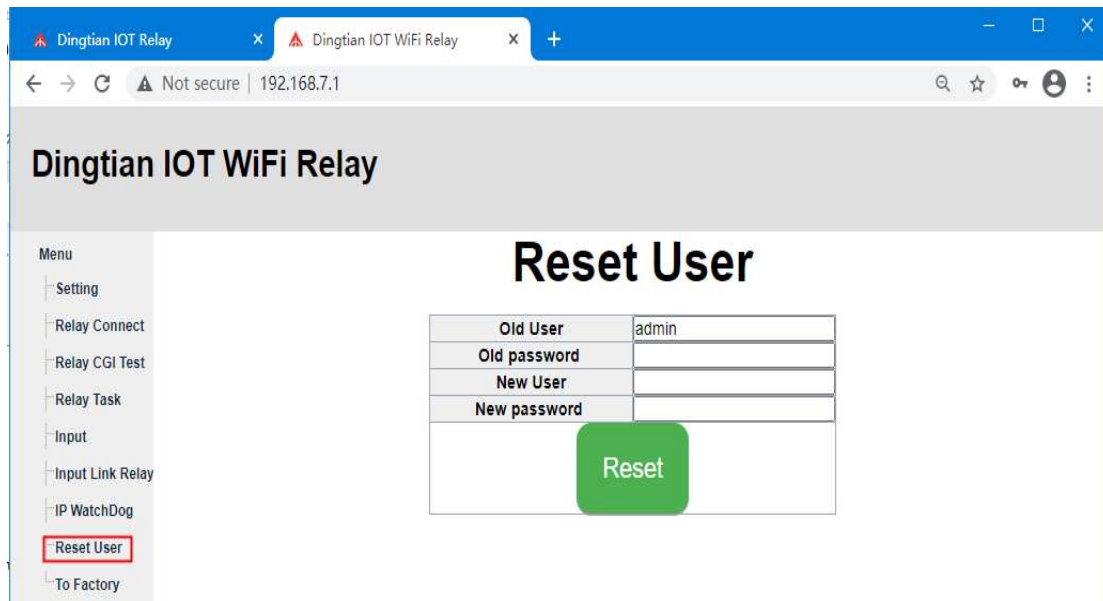

The screenshot shows a web browser window with two tabs: 'Dingtian IOT Relay' and 'Dingtian IOT WiFi Relay'. The address bar shows 'Not secure | 192.168.7.1'. The page title is 'Dingtian IOT WiFi Relay'. On the left, a 'Menu' sidebar lists various options, with 'Reset User' highlighted in a red box. The main content area is titled 'Reset User' and contains a form with the following fields:

Old User	admin
Old password	
New User	
New password	

Below the form is a green 'Reset' button.

## 5.10 To Factory

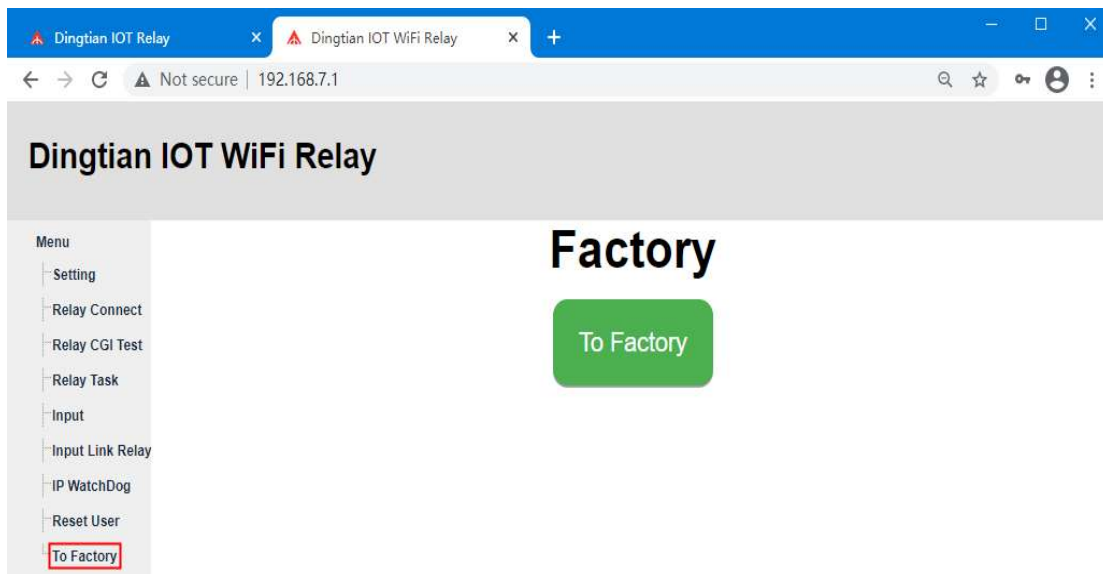

The screenshot shows the same web browser window as in the previous image. The page title is 'Dingtian IOT WiFi Relay'. In the 'Menu' sidebar, 'To Factory' is highlighted in a red box. The main content area is titled 'Factory' and contains a green 'To Factory' button.

# 6 IP Finder

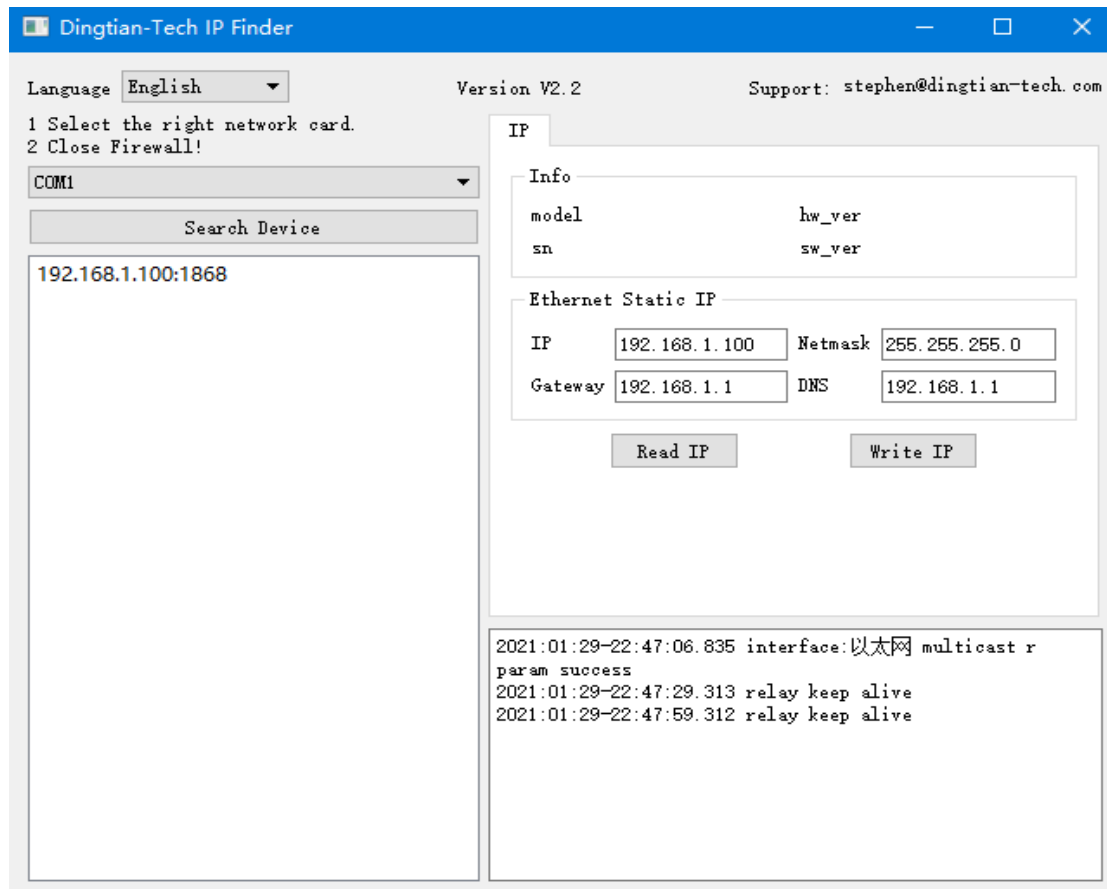

## 6.1 Search Device

**Note:** When you use IP Finder to check your relay board ip, please keep your computer just connect with one relay board and the communication of relay board just has one(only Ethernet or WIFI)

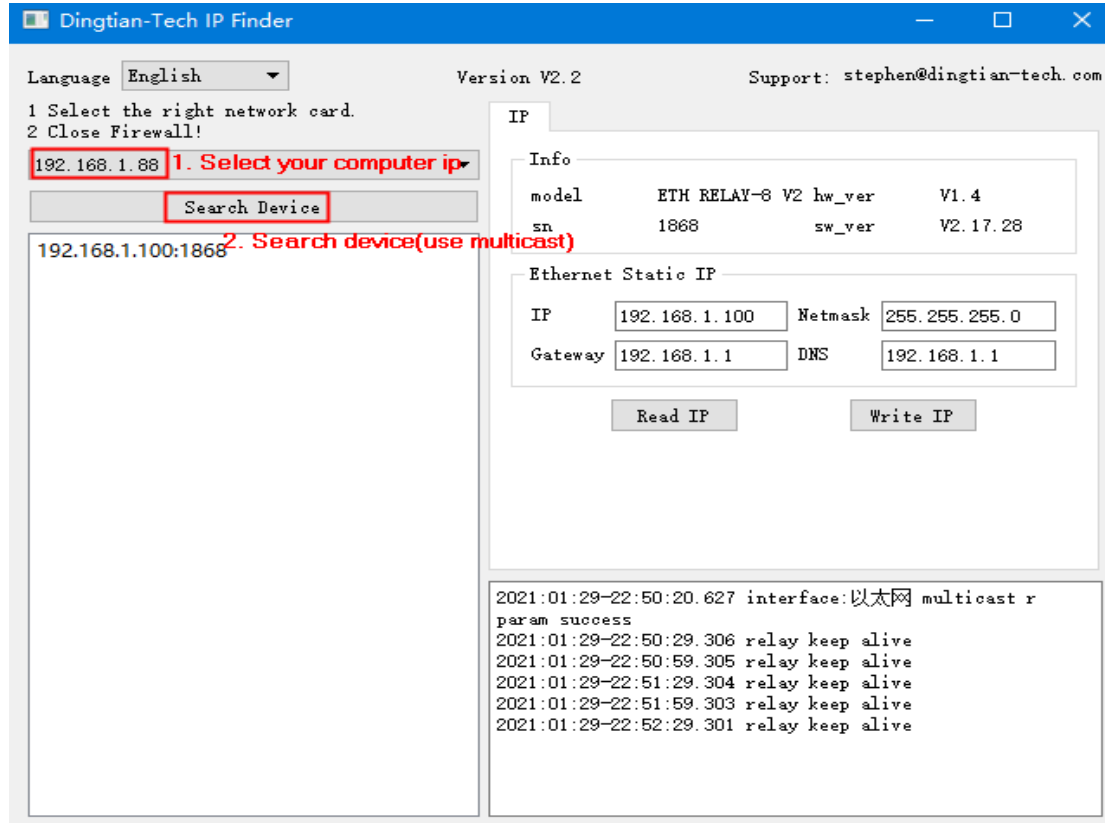

Then we can find computer ip is 192.168.1.88, relay board ip is 192.168.1.100

If your computer ip is not the same network segment as relay board, you can change the IP in Ethernet Static IP

## 6.2 Change Static IP

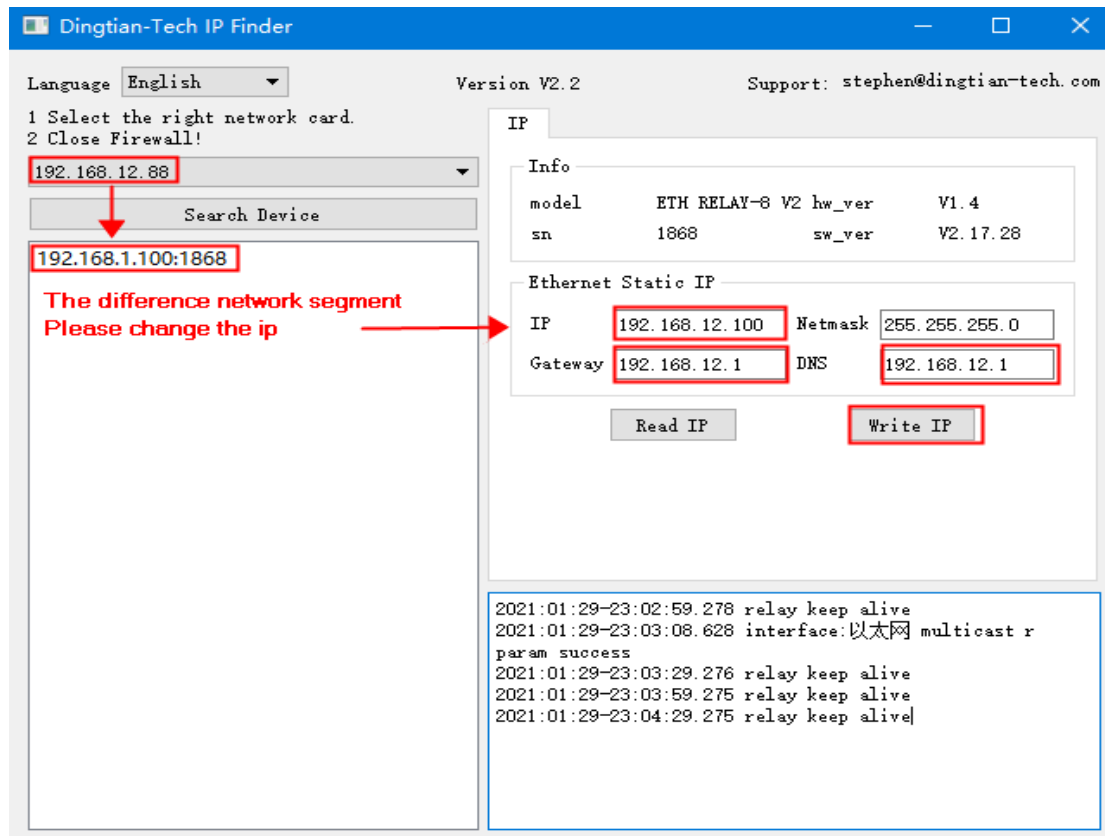

Change Static IP and Click "Write IP", then your relay board ip is 192.168.12.100

# Appendix I How to Test Command

## step 1: download SDK

we can find network tool in SDK

[http://www.dingtian-tech.com/sdk/relay\\_sdk.zip](http://www.dingtian-tech.com/sdk/relay_sdk.zip)

unzip relay\_sdk.zip

network tool name is net\_test

rs485 tool name is rs485\_test

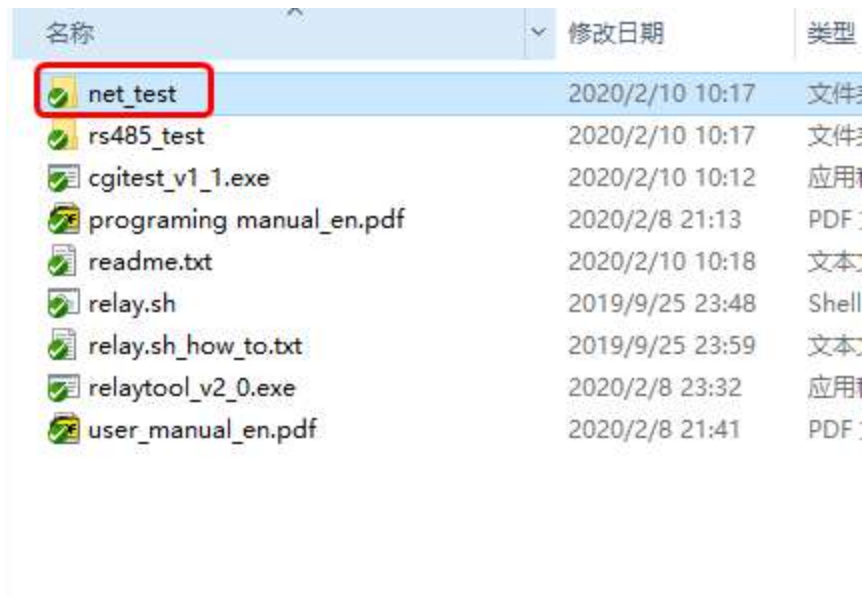

名称	修改日期	类型
net_test	2020/2/10 10:17	文件
rs485_test	2020/2/10 10:17	文件
cgitest_v1_1.exe	2020/2/10 10:12	应用
programing manual_en.pdf	2020/2/8 21:13	PDF
readme.txt	2020/2/10 10:18	文本
relay.sh	2019/9/25 23:48	Shell
relay.sh_how_to.txt	2019/9/25 23:59	文本
relaytool_v2_0.exe	2020/2/8 23:32	应用
user_manual_en.pdf	2020/2/8 21:41	PDF

Access directory "net\_test"

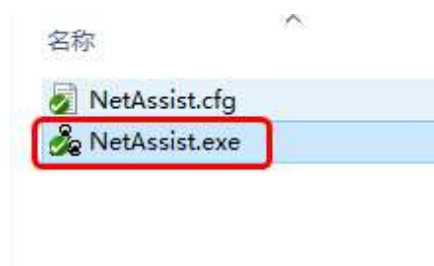

名称
NetAssist.cfg
NetAssist.exe

## step 2: Change NetAssist language

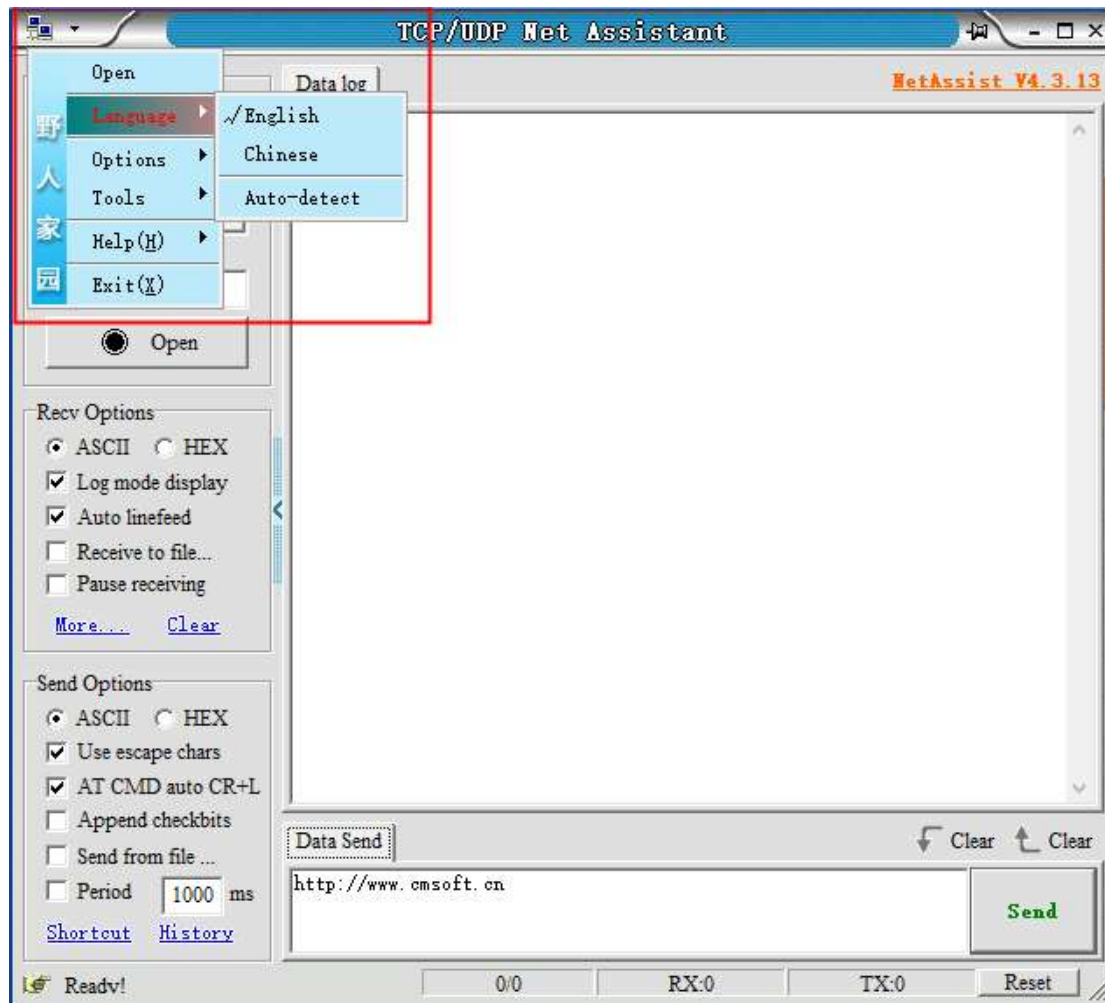



### step 3: Control relay via NetAssist network tool by wifi module

open NetAssist.exe

Shown in red box, open expansion panel

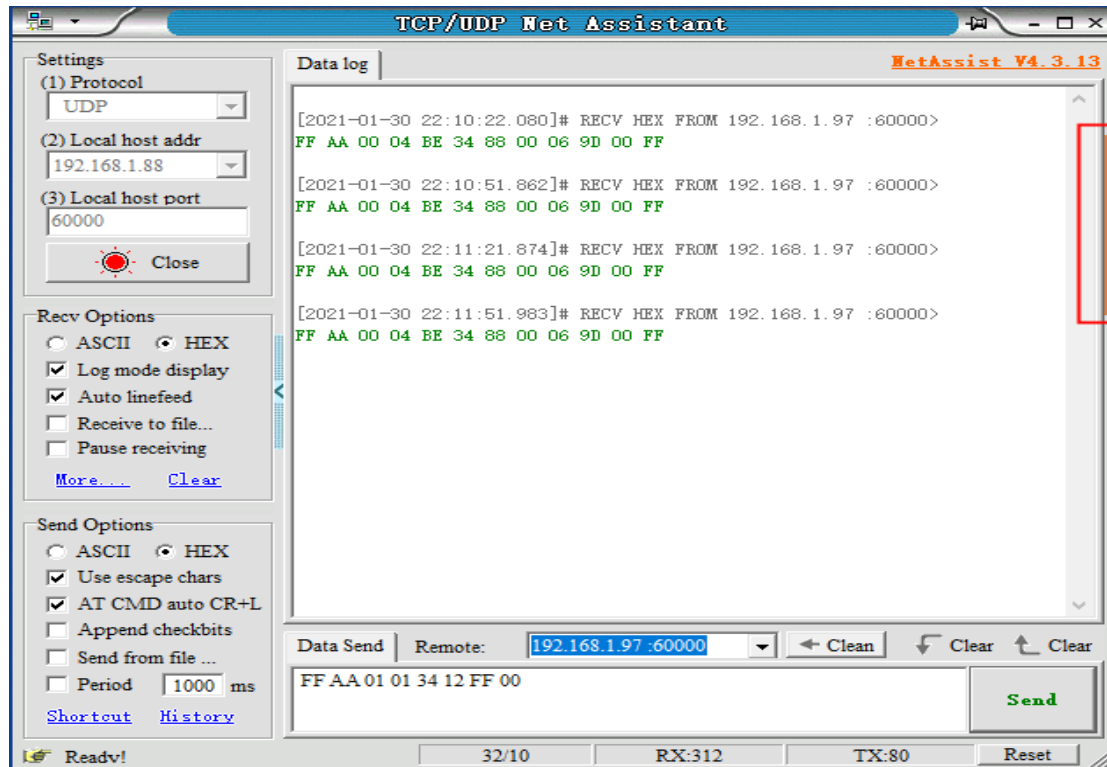

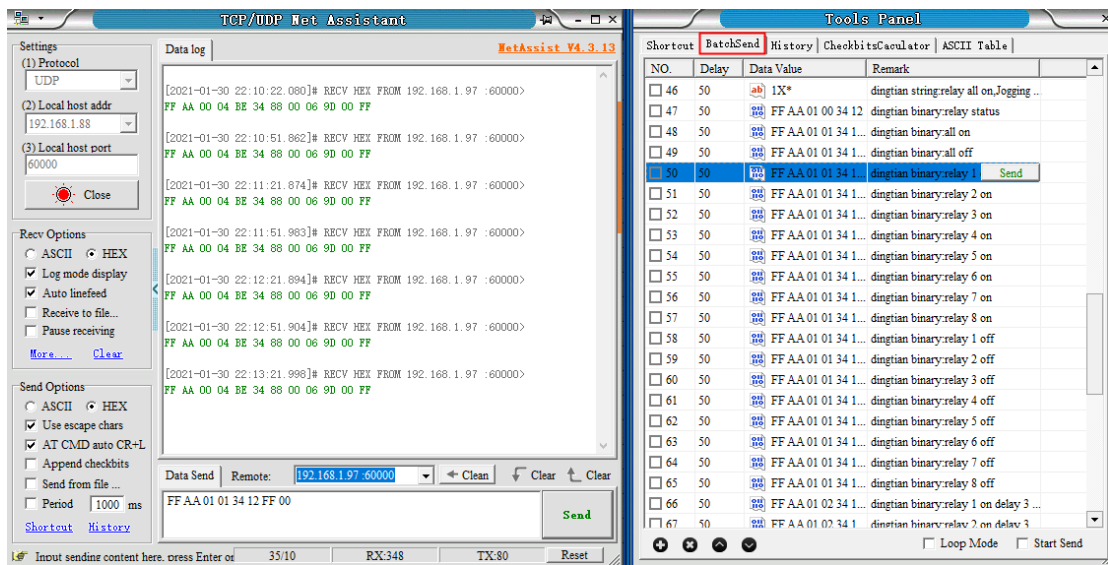
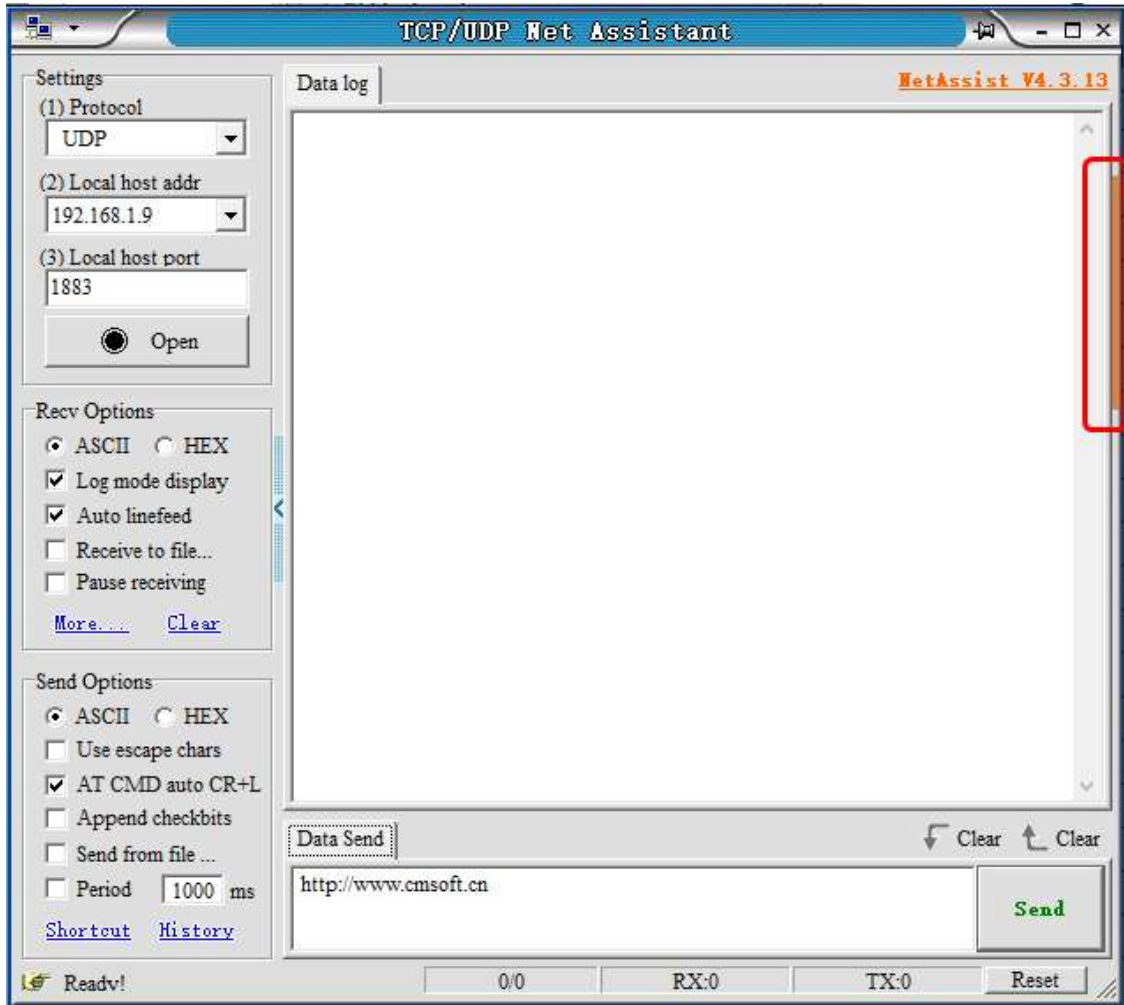

#### step 4: open UDP listen.

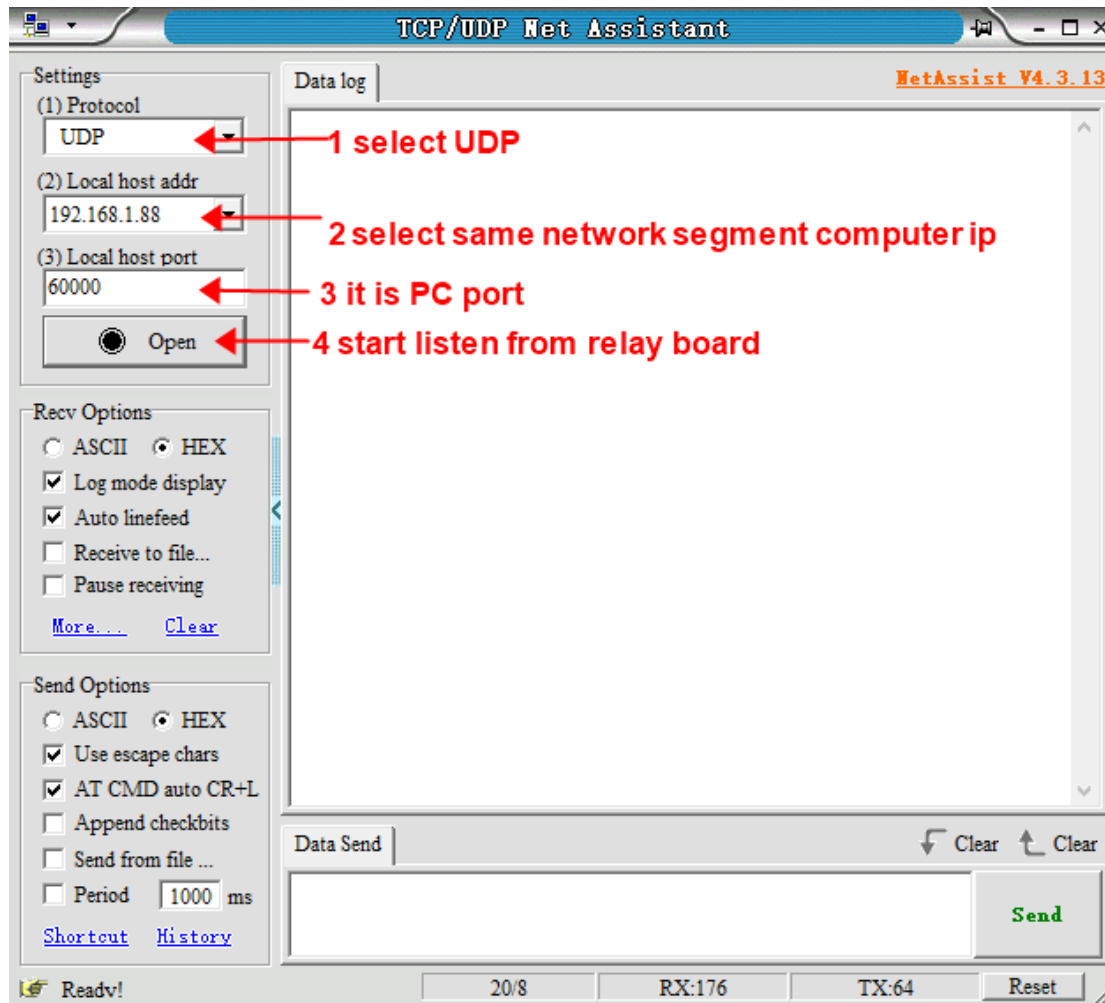

now relay board send relay status to pc via wifi module

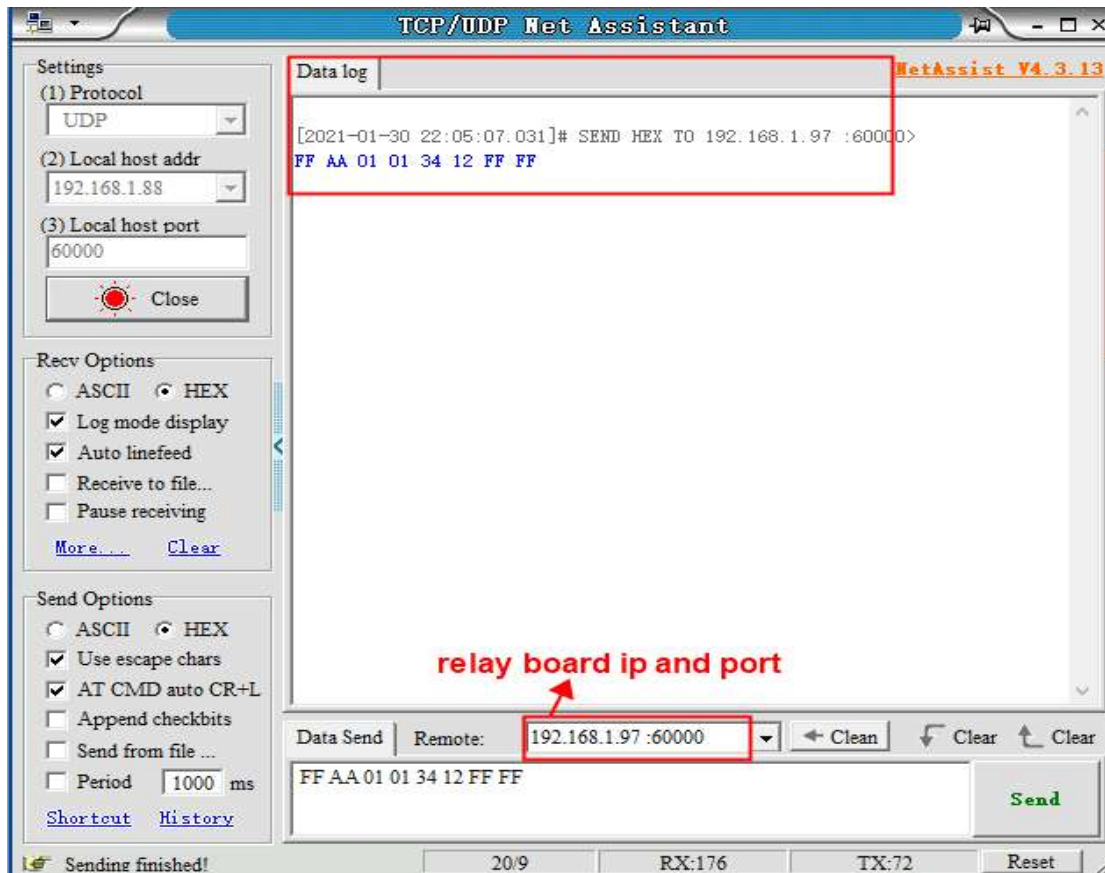

## step 5: control relay via wifi module

NetAssist tool saved preset command

we only need send to relay board via netAssist

like below set relay 1 on

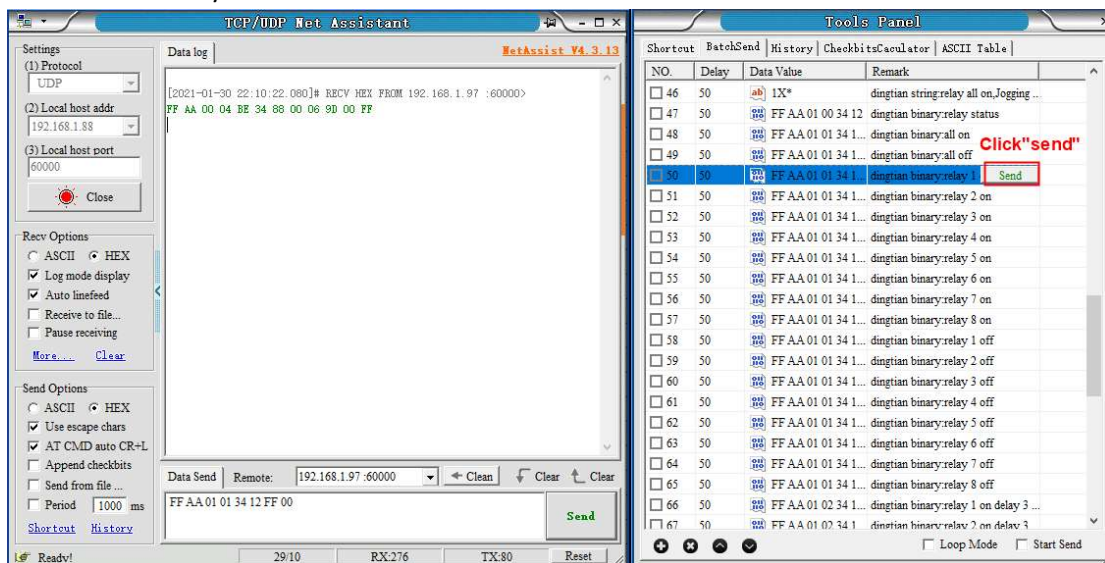

# Appendix II How to use Domoticz

Please install domotiz first

[https://releases.domoticz.com/releases/release/domoticz\\_windows\\_x86.zip](https://releases.domoticz.com/releases/release/domoticz_windows_x86.zip)

## step 1: install Dingtian plugin to Domoticz

Dingtian plugin find in SDK or github

[http://www.dingtian-tech.com/sdk/relay\\_sdk.zip](http://www.dingtian-tech.com/sdk/relay_sdk.zip)

<https://github.com/dtlzp/Domoticz-Dingtian-Relay-Plugin>

### 1 Stop Domoticz

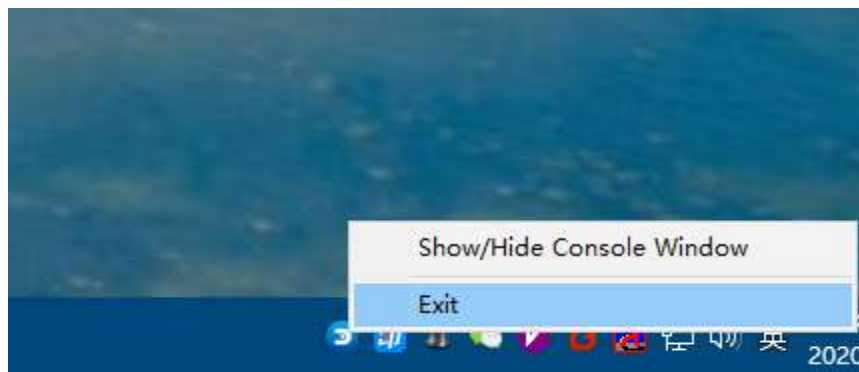

### 2 Copy Domoticz\_plugins\dingtian to Domoticz plugin dir



to Domoticz install dir

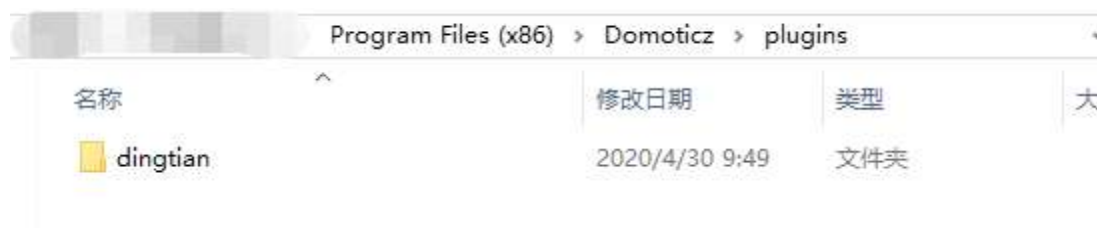

now Dingtian Relay plugin install to Domoticz successfully.

## step 2: config Dingtian Relay board

1 config relay board **UDP Server, Remote Port, Local Port, Keep Alive Second** and **Relay Password** (firmware version <= 2.16.xx)

2 config relay board **UDP Server, Remote Port, Local Port** and **Relay Password** (firmware version is 2.17.xx)

## Domoticz Ethernet

The screenshot shows the 'Relay' configuration page of the Dingtian IOT Relay. The interface is divided into several sections:

- Menu:** A sidebar on the left with options like Setting, Relay Connect (highlighted with a red box and '1'), Relay CGI Test, Relay Task, Input, Input Link Relay, IP WatchDog, Reset User, To Factory, and Reboot.
- Relay Table:** A table with columns: Channel, Protocol, Addr, Baud, Databits, Stopbits, Parity. It lists configurations for RS485, CAN, ETH-UDP1, ETH-UDP2, ETH-TCP Server, ETH-TCP Client, and ETH-MQTT. The 'Remote Address' field for ETH-UDP1 and ETH-UDP2 is highlighted with a red box and '2'. A red arrow points to the 'Remote Address' field with the text 'Domoticz server address'.
- Other:** A section with fields: Relay Password (0), Keep Alive Second (30), Jogging Time (5), Power Failure Recovery Relay (No), and Input Control Relay (Yes). The 'Keep Alive Second' field is highlighted with a red box and '3'.
- Button Type:** A section with four dropdown menus, all set to 'Momentary'.
- Save:** A green 'Save' button highlighted with a red box and '4'.
- Relay Test:** A section with eight green buttons labeled 'Relay1:Off' through 'Relay8:Off'.

# Domoticz WIFI

**Dingtian IOT WiFi Relay**

## Relay

Channel	Protocol	Remote Address	Remote Port	Local Port
WIFI-UDP1	Dingtian Binary	192.168.1.9	60000	60000
WIFI-UDP2	Dingtian String	192.168.1.9	60001	60001
WIFI-TCP Server	Modbus-TCP	Domoticz server address		Local Port 502
WIFI-TCP Client	Modbus-RTU Over TCP	Remote Address	Remote Port 502	
WIFI-MQTT	MQTT	Broker Address	Broker Port 1883	Broker Username mqtt Broker Password 123

**Other**

Relay Password	0	0~9999(0 no password)
Keep Alive Second	30	1~120 second(0 close)
Jogging Time	5	1~255 (1=100ms)

**Save**

**Relay Test**

Relay1:Off   Relay2:Off   Relay3:Off   Relay4:Off  
Relay5:Off   Relay6:Off   Relay7:Off   Relay8:Off

Dingtian Relay board web page **Relay Connect**

set **UDP Server, Remote Port, Local Port, Relay Password** and **Keep Alive Second** (donot need to set for firmware 2.17.xx)

**Notice:** **UDP Server** set to **Domoticz Server IP** Save config

## step 3: Add Dingtian Relay to Domoticz

### 1 Install Python 3.8.2

download link:

<https://www.python.org/ftp/python/3.8.2/python-3.8.2.exe>

Notice: Domoticz only support 32bit Python

after download,install it

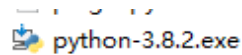

Add Python to environment

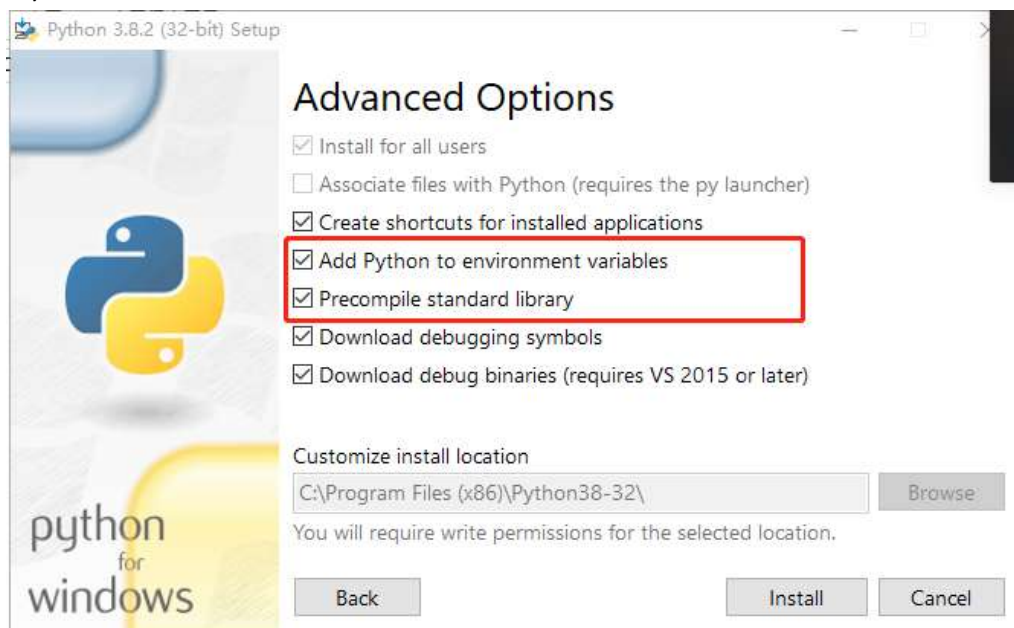

### 2 Run to Domoticz

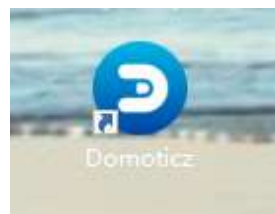



### 3 Add Dingtian Relay to Domoticz

#### 1 Find Hardware Menu

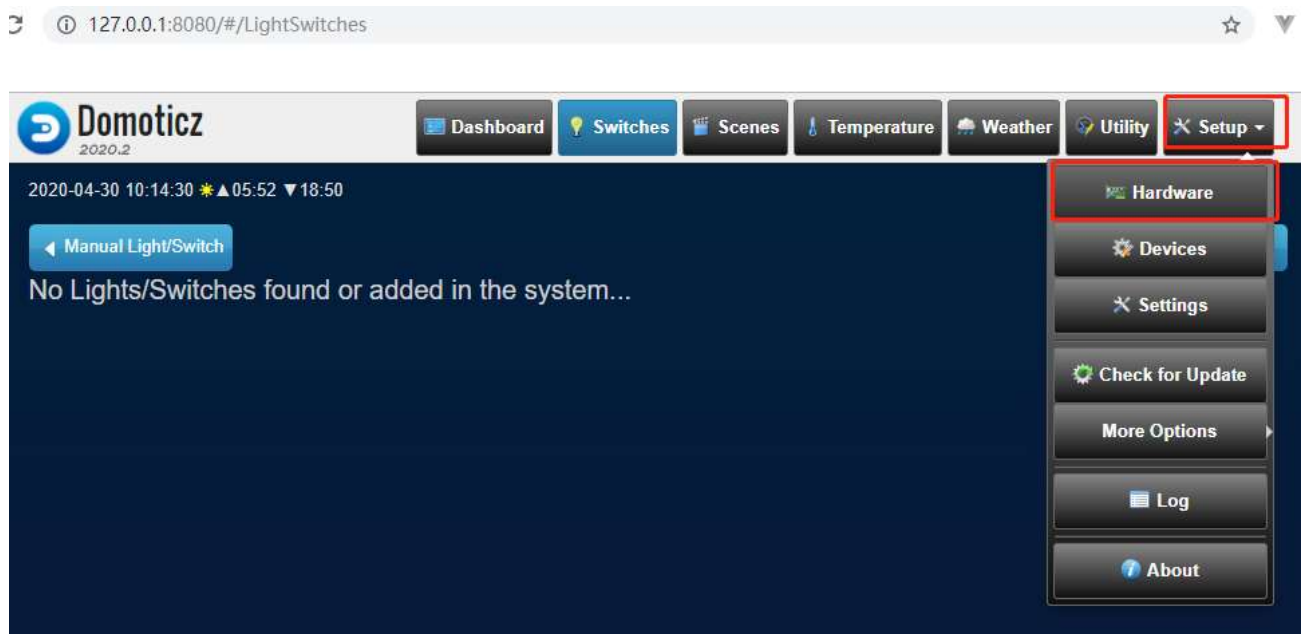

#### 2 Input Dingtian Relay config(Ethernet)

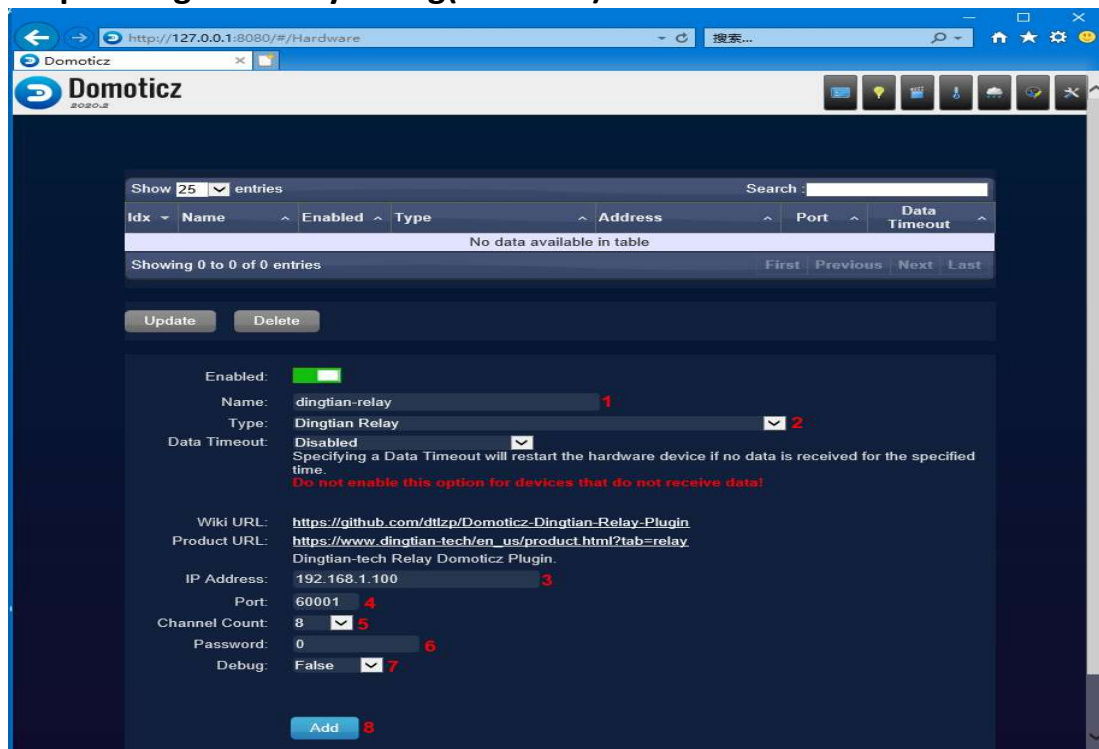

### 3.Input Dingtian Relay config(WIFI)

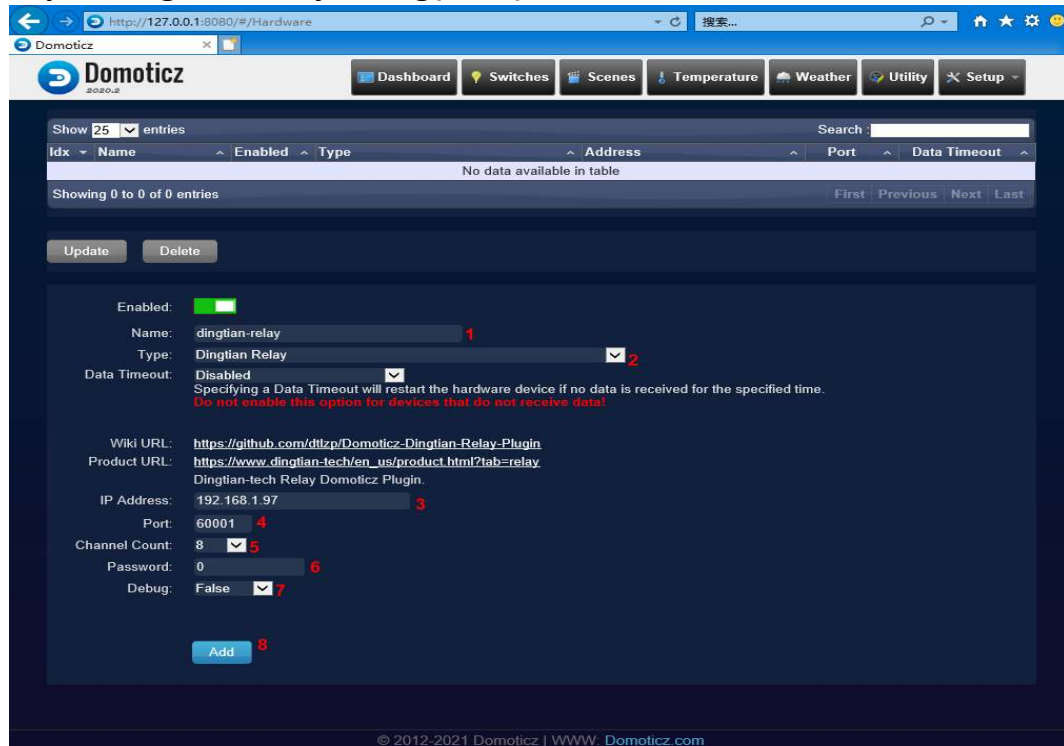

Type,IP Address,Port,Channel Count,Password must correct, Password is 1 config relay board UDP Server,Remote Port,Local Port,Keep Alive Second and Relay Password

now check parameters is ok, click "Add" to save

Now your can find Hardware and Relay

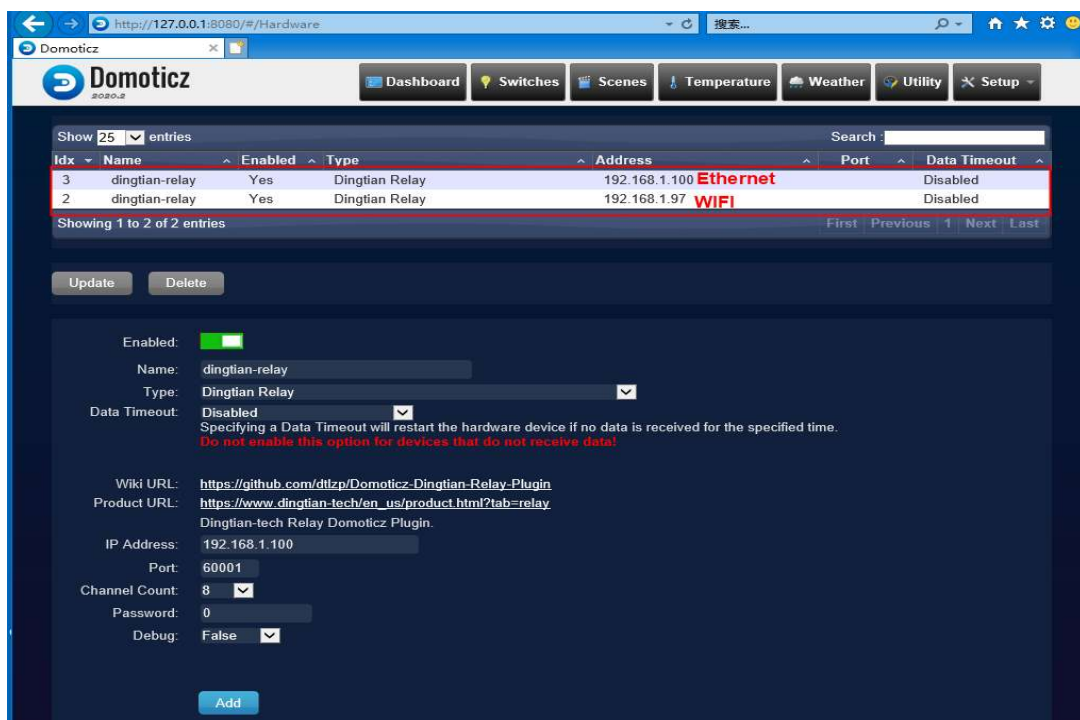

## 4 Multiple Relay board Add to Domoticz

Domoticz Need 2 UDP port for each Relay board

default is:60000 and 60001

you can add mutple with difference UDP port like:

60002 and 60003

60004 and 60005

60006 and 60007

below is example 60002 and 60003

Enabled:

Name: eth2-r8

Type: Dingtian Relay

Data Timeout: Disabled

Wiki URL: <https://github.com/dtlzp/Domoticz-Dingtian-Relay-Plugin>

Product URL: [https://www.dingtian-tech/en\\_us/product.html?tab=relay](https://www.dingtian-tech/en_us/product.html?tab=relay)

IP Address: 192.168.1.100

Port: 60003

Channel Count: 8

Password: 0

Debug: False

[Add](#)

## Relay

Channel	Protocol	Addr	Baud	Databits	Stopbits	Parity
RS485	Modbus-RTU	1	115200bps	8bit	1bit	None
CAN	Dingtian String	ID	Speed			
		1	125Kbps			
ETH-UDP1	Dingtian Binary	Remote Address		Remote Port	Local Port	
		192.168.1.88		60002	60002	
ETH-UDP2	Dingtian String	Remote Address		Remote Port	Local Port	
		192.168.1.88		60003	60003	
ETH-TCP Server	Modbus-TCP				Local Port	
					502	
ETH-TCP Client	Modbus-RTU Over TCP	Remote Address		Remote Port		
		192.168.1.9		502		
ETH-MQTT	MQTT	Broker Address		Broker Port	Broker Username	Broker Password
		192.168.1.88		1883	mqtt	123

## 5 Add Relay to Switches Page

→ 127.0.0.1:8080/#/Devices

Domoticz 2020.2

Dashboard Switches Scenes Temperature Weather Utility **Setup**

Hardware Refresh

Devices

Settings

Check for Update

More Options

Log

About

Idx	Hardware	ID	Unit	Name	Type	SubType	Data	...
7	dingtian-relay	00020007	7	dingtian-relay - RELAY7	Light/Switch	Switch	Off	-
8	dingtian-relay	00020008	8	dingtian-relay - RELAY8	Light/Switch	Switch	Off	-
2	dingtian-relay	00020002	2	dingtian-relay - RELAY2	Light/Switch	Switch	Off	-
3	dingtian-relay	00020003	3	dingtian-relay - RELAY3	Light/Switch	Switch	Off	-
4	dingtian-relay	00020004	4	dingtian-relay - RELAY4	Light/Switch	Switch	Off	-
5	dingtian-relay	00020005	5	dingtian-relay - RELAY5	Light/Switch	Switch	Off	-
6	dingtian-relay	00020006	6	dingtian-relay - RELAY6	Light/Switch	Switch	Off	-
1	dingtian-relay	00020001	1	dingtian-relay - RELAY1	Light/Switch	Switch	Off	-

Showing 1 to 8 of 8 entries

Click Add Device to use Relay

→ 127.0.0.1:8080/#/Devices

Domoticz 2020.2

Dashboard Switches Scenes Temperature Weather Utility Setup

All Devices Not Used Refresh

Show 25 entries Search:

Idx	Hardware	ID	Unit	Name	Type	SubType	Data	...	Last Seen
7	dingtian-relay	00020007	7	dingtian-relay - RELAY7	Light/Switch	Switch	Off	-	2020-04-30 10:26:14
8	dingtian-relay	00020008	8	dingtian-relay - RELAY8	Light/Switch	Switch	Off	-	2020-04-30 10:26:14
2	dingtian-relay	00020002	2	dingtian-relay - RELAY2	Light/Switch	Switch	Off	-	2020-04-30 10:26:13
3	dingtian-relay	00020003	3	dingtian-relay - RELAY3	Light/Switch	Switch	Off	-	2020-04-30 10:26:13
4	dingtian-relay	00020004	4	dingtian-relay - RELAY4	Light/Switch	Switch	Off	-	2020-04-30 10:26:13
5	dingtian-relay	00020005	5	dingtian-relay - RELAY5	Light/Switch	Switch	Off	-	2020-04-30 10:26:13
6	dingtian-relay	00020006	6	dingtian-relay - RELAY6	Light/Switch	Switch	Off	-	2020-04-30 10:26:13
1	dingtian-relay	00020001	1	dingtian-relay - RELAY1	Light/Switch	Switch	Off	-	2020-04-30 10:26:12

Showing 1 to 8 of 8 entries

Click Add Device to confirm

→ 127.0.0.1:8080/#/Devices

应用

Domoticz 2020.2

Dashboard Switches Scenes Temperature Weather Utility Setup

Used All Devices Not Used Refresh

Show 25 entries

Add Device

Name: dingtian-relay - RELAY7

As:  Main Device  Sub/Slave Device

Add Device Cancel

Idx	Hardware	ID	Unit	Name	Type	SubType	Data	Last Seen
7	dingtian-relay	00020007	7	dingtian-relay - RELAY7	Light/Switch	Switch	Off	2020-04-30 10:26:14
8	dingtian-relay	00020008	8	dingtian-relay - RELAY8	Light/Switch	Switch	Off	2020-04-30 10:26:14
2	dingtian-relay	00020002	2	dingtian-relay - RELAY2	Light/Switch	Switch	Off	2020-04-30 10:26:13
3	dingtian-relay	00020003	3	dingtian-relay - RELAY3	Light/Switch	Switch	Off	2020-04-30 10:26:13
4	dingtian-relay	00020004	4	dingtian-relay - RELAY4	Light/Switch	Switch	Off	2020-04-30 10:26:13
5	dingtian-relay	00020005	5	dingtian-relay - RELAY5	Light/Switch	Switch	Off	2020-04-30 10:26:13
6	dingtian-relay	00020006	6	dingtian-relay - RELAY6	Light/Switch	Switch	Off	2020-04-30 10:26:13
1	dingtian-relay	00020001	1	dingtian-relay - RELAY1	Light/Switch	Switch	Off	2020-04-30 10:26:12

Showing 1 to 8 of 8 entries

result

→ 127.0.0.1:8080/#/Devices

应用

Domoticz 2020.2

Dashboard Switches Scenes Temperature Weather Utility Setup

Used All Devices Not Used Refresh

Show 25 entries

Idx	Hardware	ID	Unit	Name	Type	SubType	Data	Last Seen
7	dingtian-relay	00020007	7	dingtian-relay - RELAY7	Light/Switch	Switch	Off	2020-04-30 10:26:14
8	dingtian-relay	00020008	8	dingtian-relay - RELAY8	Light/Switch	Switch	Off	2020-04-30 10:26:14
2	dingtian-relay	00020002	2	dingtian-relay - RELAY2	Light/Switch	Switch	Off	2020-04-30 10:26:13
3	dingtian-relay	00020003	3	dingtian-relay - RELAY3	Light/Switch	Switch	Off	2020-04-30 10:26:13
4	dingtian-relay	00020004	4	dingtian-relay - RELAY4	Light/Switch	Switch	Off	2020-04-30 10:26:13
5	dingtian-relay	00020005	5	dingtian-relay - RELAY5	Light/Switch	Switch	Off	2020-04-30 10:26:13
6	dingtian-relay	00020006	6	dingtian-relay - RELAY6	Light/Switch	Switch	Off	2020-04-30 10:26:13
1	dingtian-relay	00020001	1	dingtian-relay - RELAY1	Light/Switch	Switch	Off	2020-04-30 10:26:12

Showing 1 to 8 of 8 entries

## 4 Control Dingtian Relay with Domoticz

Switch “Switches” page

127.0.0.1:8080/#/LightSwitches

Domoticz 2020.2

Dashboard Switches Scenes Temperature Weather Utility Setup

2020-04-30 10:35:20 \*▲05:52 ▼18:50

Manual Light/Switch Learn Light/Switch

dingtian-relay - RELAY1 Off  
Last Seen: 2020-04-30 10:26:12  
Type: Light/Switch, Switch, On/Off  
Log Edit Timers Notifications

dingtian-relay - RELAY2 Off  
Last Seen: 2020-04-30 10:26:13  
Type: Light/Switch, Switch, On/Off  
Log Edit Timers Notifications

dingtian-relay - RELAY3 Off  
Last Seen: 2020-04-30 10:26:13  
Type: Light/Switch, Switch, On/Off  
Log Edit Timers Notifications

dingtian-relay - RELAY4 Off  
Last Seen: 2020-04-30 10:26:13  
Type: Light/Switch, Switch, On/Off  
Log Edit Timers Notifications

dingtian-relay - RELAY5 Off  
Last Seen: 2020-04-30 10:26:13  
Type: Light/Switch, Switch, On/Off  
Log Edit Timers Notifications

dingtian-relay - RELAY6 Off  
Last Seen: 2020-04-30 10:26:13  
Type: Light/Switch, Switch, On/Off  
Log Edit Timers Notifications

dingtian-relay - RELAY7 Off  
Last Seen: 2020-04-30 10:26:14  
Type: Light/Switch, Switch, On/Off  
Log Edit Timers Notifications

dingtian-relay - RELAY8 Off  
Last Seen: 2020-04-30 10:26:14  
Type: Light/Switch, Switch, On/Off  
Log Edit Timers Notifications

Click light icon to control relay

127.0.0.1:8080/#/LightSwitches

Domoticz 2020.2

Dashboard Switches Scenes Temperature Weather Utility Setup

2020-04-30 10:36:10 \*▲05:52 ▼18:50

Manual Light/Switch Learn Light/Switch

dingtian-relay - RELAY1 Off  
Last Seen: 2020-04-30 10:26:12  
Type: Light/Switch, Switch, On/Off  
Turn On  
Log Edit Timers Notifications

dingtian-relay - RELAY2 Off  
Last Seen: 2020-04-30 10:26:13  
Type: Light/Switch, Switch, On/Off  
Log Edit Timers Notifications

dingtian-relay - RELAY3 Off  
Last Seen: 2020-04-30 10:26:13  
Type: Light/Switch, Switch, On/Off  
Log Edit Timers Notifications

dingtian-relay - RELAY4 Off  
Last Seen: 2020-04-30 10:26:13  
Type: Light/Switch, Switch, On/Off  
Log Edit Timers Notifications

dingtian-relay - RELAY5 Off  
Last Seen: 2020-04-30 10:26:13  
Type: Light/Switch, Switch, On/Off  
Log Edit Timers Notifications

dingtian-relay - RELAY6 Off  
Last Seen: 2020-04-30 10:26:13  
Type: Light/Switch, Switch, On/Off  
Log Edit Timers Notifications

dingtian-relay - RELAY7 Off  
Last Seen: 2020-04-30 10:26:14  
Type: Light/Switch, Switch, On/Off  
Log Edit Timers Notifications

dingtian-relay - RELAY8 Off  
Last Seen: 2020-04-30 10:26:14  
Type: Light/Switch, Switch, On/Off  
Log Edit Timers Notifications

2020-04-30 10:37:40   05:52  18:50

Manual Light/Switch

[Learn Light/Switch](#)

**dingtian-relay - RELAY1** On

 Last Seen: 2020-04-30 10:37:36  
Type: Light/Switch, Switch, On/Off

 [Log](#) [Edit](#) [Timers](#) [Notifications](#)

**dingtian-relay - RELAY2** Off

 Last Seen: 2020-04-30 10:26:13  
Type: Light/Switch, Switch, On/Off

 [Log](#) [Edit](#) [Timers](#) [Notifications](#)

**dingtian-relay - RELAY3** Off

 Last Seen: 2020-04-30 10:26:13  
Type: Light/Switch, Switch, On/Off

 [Log](#) [Edit](#) [Timers](#) [Notifications](#)

**dingtian-relay - RELAY4** Off

 Last Seen: 2020-04-30 10:26:13  
Type: Light/Switch, Switch, On/Off

 [Log](#) [Edit](#) [Timers](#) [Notifications](#)

**dingtian-relay - RELAY5** Off

 Last Seen: 2020-04-30 10:26:13  
Type: Light/Switch, Switch, On/Off

 [Log](#) [Edit](#) [Timers](#) [Notifications](#)

**dingtian-relay - RELAY6** Off

 Last Seen: 2020-04-30 10:26:13  
Type: Light/Switch, Switch, On/Off

 [Log](#) [Edit](#) [Timers](#) [Notifications](#)

**dingtian-relay - RELAY7** Off

 Last Seen: 2020-04-30 10:26:14  
Type: Light/Switch, Switch, On/Off

 [Log](#) [Edit](#) [Timers](#) [Notifications](#)

**dingtian-relay - RELAY8** Off

 Last Seen: 2020-04-30 10:37:28  
Type: Light/Switch, Switch, On/Off

 [Log](#) [Edit](#) [Timers](#) [Notifications](#)

## step 4: Domoticz mobile application

Please follow up step 1/2/3 firstly to confirm PC Domoticz connect

### 1 Set the Location, User name and password on PC Domoticz

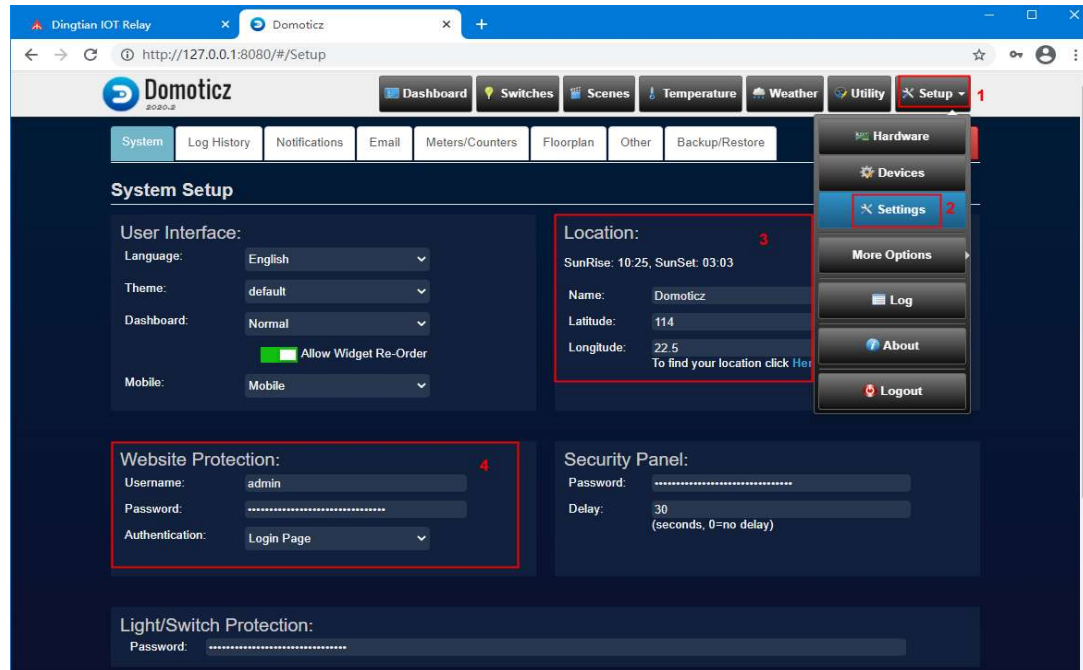

## 2 Install Domoticz

Android google play "Domoticz Home Automation Lite", which is free of charge and cannot refresh automatically. So please refresh by manual after do it





### 3 Set Domoticz Server parameter

Server Name  
domoticz server

---

Server address  
192.168.1.88

---

Port  
8080

HTTP ▼

---

Username  
admin

Password  
.....

Show password

---

Directory

---

Different server address  
Use different address for local connection

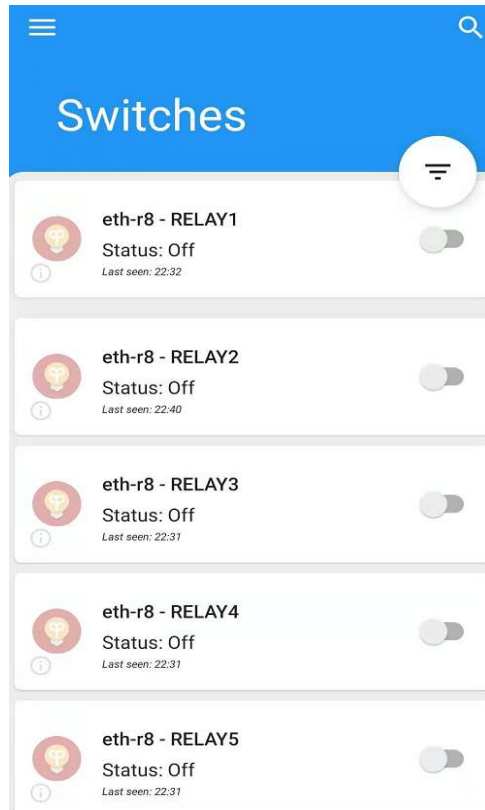

Domoticz mobile connect successfully, then you can control the switch by mobile phone

# Appendix III How to MQTT

## MQTT Ethernet

The screenshot shows a web browser window with two tabs: 'Dingtian IOT Relay' and 'Dingtian IOT WiFi Relay'. The address bar shows '192.168.1.100/menu\_page.html'. The page title is 'Dingtian IOT Relay'. On the left is a 'Menu' sidebar with options: Setting, Relay Connect, Relay CGI Test, Relay Task, Input, Input Link Relay, IP WatchDog, Reset User, To Factory, and Reboot. The main content area is titled 'Setting' and contains a table of system parameters. The 'Serial Number' field is highlighted with a red box. Below the table is a green 'Save' button.

Hardware Version	V1.4
Software Version	V2.17.28
Build Date	2021-01-21 21:23:13
Model	Dingtian IOT RELAY-8
Serial Number	1868
Date Time	1/30/2021, 22:47:00
NTP Server	pool.ntp.org
Hostname	Dingtian-Relay1868
Hostname+Suffix	Dingtian-Relay + SN
HTTP Server Port	80
DHCP	No
IP	192.168.1.100
Netmask	255.255.255.0
Gateway	192.168.1.1
DNS	192.168.1.1
MAC	bc:34:88:00:06:9d
WiFi AP IP	192.168.7.1
WiFi STA IP	192.168.1.97

Save

# MQTT WIFI

Dingtian IOT Relay x Dingtian IOT WiFi Relay x +

← → ↻ Not secure | 192.168.1.100/menu\_page.html 🔍 ☆ ⚙️ 👤 ⋮

## Dingtian IOT Relay

Menu

- Setting
- Relay Connect
- Relay CGI Test
- Relay Task
- Input
- Input Link Relay
- IP WatchDog
- Reset User
- To Factory
- Reboot

# Setting

Hardware Version	V1.4
Software Version	V2.17.28
Build Date	2021-01-21 21:23:13
Model	Dingtian IOT RELAY-8
Serial Number	1868
Date Time	1/30/2021, 22:47:00
NTP Server	pool.ntp.org
Hostname	Dingtian-Relay1868
Hostname+Suffix	Dingtian-Relay + SN ▾
HTTP Server Port	80
DHCP	No ▾
IP	192.168.1.100
Netmask	255.255.255.0
Gateway	192.168.1.1
DNS	192.168.1.1
MAC	bc:34:88:00:06:9d
WiFi AP IP	192.168.7.1
WiFi STA IP	192.168.1.97

Save

Relay board Ethernet MQTT Client Id

dingtian-relay+SN

Relay board WiFi MQTT Client Id

dingtian-wrelay+SN

example:

below relay board "Serial Number" is 1868

so ETH MQTT client id is:dingtian-relay1868

so WiFi MQTT client id is:dingtian-wrelay1868

Relay board MQTT Topic and Publish format:

below V2.15.869

/dingtian/relay/in/control

/dingtian/relay/out/relayX

above V2.15.869

/dingtian/relaySN/in/control

/dingtian/relaySN/out/relayX

above V2.17.xx

ETH

/dingtian/relaySN/in/control

/dingtian/relaySN/in/rX

/dingtian/relaySN/out/rX

/dingtian/relaySN/out/iX

/dingtian/relaySN/out/relayX

/dingtian/relaySN/out/inputX

/dingtian/relaySN/out/ip

/dingtian/relaySN/out/sn

/dingtian/relaySN/out/mac

/dingtian/relaySN/out/input\_cnt

/dingtian/relaySN/out/relay\_cnt

WiFi

/dingtian/wrelaySN/in/control

/dingtian/wrelaySN/in/rX

/dingtian/wrelaySN/out/rX

/dingtian/wrelaySN/out/iX

/dingtian/wrelaySN/out/relayX

/dingtian/wrelaySN/out/inputX

/dingtian/wrelaySN/out/ip

/dingtian/wrelaySN/out/sn

/dingtian/wrelaySN/out/mac

/dingtian/wrelaySN/out/input\_cnt

/dingtian/wrelaySN/out/relay\_cnt

example:

below V2.15.869

/dingtian/relay/in/control  
/dingtian/relay/out/relay1  
/dingtian/relay/out/relay2  
/dingtian/relay/out/relay3  
/dingtian/relay/out/relay4  
/dingtian/relay/out/relay5  
/dingtian/relay/out/relay6  
/dingtian/relay/out/relay7  
/dingtian/relay/out/relay8

above V2.15.869

/dingtian/relay1868/in/control  
/dingtian/relay1868/out/relay1  
/dingtian/relay1868/out/relay2  
/dingtian/relay1868/out/relay3  
/dingtian/relay1868/out/relay4  
/dingtian/relay1868/out/relay5  
/dingtian/relay1868/out/relay6  
/dingtian/relay1868/out/relay7  
/dingtian/relay1868/out/relay8

above V2.17.xx

ETH

/dingtian/relay1868/in/control  
/dingtian/relay1868/in/r1~8  
/dingtian/relay1868/out/r1~8  
/dingtian/relay1868/out/i1~8  
/dingtian/relay1868/out/relay1~8  
/dingtian/relay1868/out/input1~8  
/dingtian/relay1868/out/ip  
/dingtian/relay1868/out/sn  
/dingtian/relay1868/out/mac  
/dingtian/relay1868/out/input\_cnt  
/dingtian/relay1868/out/relay\_cnt

WIFI

/dingtian/wrelay1868/in/control  
/dingtian/wrelay1868/in/r1~8  
/dingtian/wrelay1868/out/r1~8  
/dingtian/wrelay1868/out/i1~8  
/dingtian/wrelay1868/out/relay1~8  
/dingtian/wrelay1868/out/input1~8

/dingtian/wrelay1868/out/ip  
/dingtian/wrelay1868/out/sn  
/dingtian/wrelay1868/out/mac  
/dingtian/wrelay1868/out/input\_cnt  
/dingtian/wrelay1868/out/relay\_cnt

**Relay board MQTT Topic to subscribe:**

/dingtian/relay/in/control  
or  
/dingtian/relay1868/in/control

type:ON/OFF,DELAY,JOGGING  
idx:1~8  
status:ON,OFF  
time: (ON/OFF)0,(DELAY)1~65535second,(JOGGING)1~255\*100ms  
pass:0~9999

example:

```
{"type":"ON/OFF","idx":'1',"status':"ON',"time':"0',"pass':"0"}  
{"type":"DELAY","idx":'2',"status':"ON',"time':"5',"pass':"0"}  
{"type":"JOGGING","idx":'3',"status':"ON',"time':"5',"pass':"0"}  
{"type":"ON/OFF","idx":'4',"status':"OFF',"time':"0',"pass':"0"}
```

**Relay board MQTT Topic to publish:**

/dingtian/relay/out/relay1  
/dingtian/relay/out/relay2  
/dingtian/relay/out/relay3  
/dingtian/relay/out/relay4  
/dingtian/relay/out/relay5  
/dingtian/relay/out/relay6  
/dingtian/relay/out/relay7  
/dingtian/relay/out/relay8  
or  
/dingtian/relay1868/out/relay1  
/dingtian/relay1868/out/relay2  
/dingtian/relay1868/out/relay3  
/dingtian/relay1868/out/relay4  
/dingtian/relay1868/out/relay5  
/dingtian/relay1868/out/relay6  
/dingtian/relay1868/out/relay7  
/dingtian/relay1868/out/relay8  
or  
/dingtian/relay1868/out/r1~8  
/dingtian/relay1868/out/i1~8

/dingtian/relay1868/out/relay1~8  
/dingtian/relay1868/out/input1~8  
/dingtian/relay1868/out/ip  
/dingtian/relay1868/out/sn  
/dingtian/relay1868/out/mac  
/dingtian/relay1868/out/input\_cnt  
/dingtian/relay1868/out/relay\_cnt

idx:1~8  
status:ON,OFF

example:

```
{"idx": "1", "status": "OFF"}
```

## step 1: Install and config Broker

 mosquitto-1.6.9-install-windows-x64.exe

1 config "mosquitto.conf"  
bind\_address 0.0.0.0  
port 1883

2 start windows Service "mosquitto"

 mosquitto

Mosquitto Broker

## step 2: Install MQTT PC client

 client\_MQTTBox-win.exe

## step 3: MQTTBox Add Client



Protocol:mqtt/tcp  
Host:192.168.1.88:1883(Broker server ip and port)  
Username:mqtt  
Password:123  
Broker MQTT V3.1.1 compliant

MQTT Client Name: relay\_board

MQTT Client Id: c27e3dba-456d-47d3-9209-1bt

Append timestamp to MQTT client id?  Yes

Broker is MQTT v3.1.1 compliant?  Yes

Protocol: mqtt / tcp

Host: 192.168.1.88:1883

Clean Session?  Yes

Auto connect on app launch?  Yes

Username: mqtt

Password: ...

Reschedule Pings?  Yes

Queue outgoing QoS zero messages?  Yes

Reconnect Period (milliseconds): 1000

Connect Timeout (milliseconds): 30000

KeepAlive (seconds): 10

Will - Topic: Will - Topic

Will - QoS: 1 - Atleast Once

Will - Retain:  Yes

Will - Payload:

Config Relay board Web page MQTT parameter

### Dingtian IOT Relay

Menu

- Setting
- Relay Connect
- Relay CGI Test
- Relay Task
- Input
- Input Link Relay
- IP WatchDog
- Reset User
- To Factory
- Reboot

## Relay

Channel	Protocol	Addr	Baud	Databits	Stopbits	Parity
RS485	Modbus-RTU	1	115200bps	8bit	1bit	None
CAN	Dingtian String	ID	Speed			
ETH-UDP1	Dingtian Binary	Remote Address	Remote Port	Local Port		
ETH-UDP2	Dingtian String	Remote Address	Remote Port	Local Port		
ETH-TCP Server	Modbus-TCP		Local Port			
ETH-TCP Client	Modbus-RTU Over TCP	Remote Address	Remote Port			
ETH-MQTT	MQTT	Broker Address	Broker Port	Broker Username	Broker Password	

**Other**

Relay Password: 0 (0~9999(0 no password))

Keep Alive Second: 30 (1~120 second(0 close))

Jogging Time: 5 (1~255 (1=100ms))

Power Failure Recovery Relay: No

Input Control Relay: Yes

**Button Type**

Momentary Momentary Momentary Momentary

Momentary Momentary Momentary Momentary

**Relay Test**

Relay1:Off Relay2:Off Relay3:Off Relay4:Off

Relay5:Off Relay6:Off Relay7:Off Relay8:Off



## step 4: MQTTBox Publish topic to relay board and subscribe topic

The screenshot shows the MQTTBox application interface. At the top, there is a status bar with 'Connected' and buttons for 'Add publisher' and 'Add subscriber'. Below this, there are two panels for publishing and two panels for subscriptions.

**Top Left Panel (Publish):**

- Topic to publish: `/dingtian/relay1868/in/r8`
- QoS: 2 - Exactly Once
- Retain:
- Payload Type: Strings / JSON / XML / Characters
- Payload: `ON`
- Buttons: Publish
- Preview: `ON`  
`topic:/dingtian/relay1868/in/r8, qos:2, retain:false`

**Top Right Panel (Publish):**

- Topic to publish: `/dingtian/relay1868/in/control`
- QoS: 0 - Almost Once
- Retain:
- Payload Type: Strings / JSON / XML / Characters
- Payload: `{"type":"ON/OFF","idx":"3","status":"ON","time":"0","pass":"0"}`
- Buttons: Publish
- Preview: `{"type":"ON/OFF","idx":"3","status":"ON","time":"0","pass":"0"}`  
`topic:/dingtian/relay1868/in/control, qos:0, retain:false`

**Bottom Left Panel (Subscribe):**

- Topic: `/dingtian/relay1868/out/r1`
- Preview: `OFF`  
`qos : 1, retain : false, cmd : publish, dup : false, topic : /dingtian/relay1868/out/r1, messageid : 8, length : 33, Raw payload : 797070`

**Bottom Right Panel (Subscribe):**

- Topic: `/dingtian/relay1868/out/relay3`
- Preview: (Empty)

# Appendix IV How to CoAP

you need linux system

## step 1: compile libcoap

```
git clone --recurse-submodules https://github.com/obgm/libcoap
./autogen.sh
./configure --disable-manpages --enable-examples --enable-tests
make
```

## step 2: CoAP Get relay status

Relay Status(1:ON, 0:OFF)

```
./coap-client -m get coap://192.168.1.100/dingtian/r1
./coap-client -m get coap://192.168.1.100/dingtian/r2
./coap-client -m get coap://192.168.1.100/dingtian/r3
./coap-client -m get coap://192.168.1.100/dingtian/r4
./coap-client -m get coap://192.168.1.100/dingtian/r5
./coap-client -m get coap://192.168.1.100/dingtian/r6
./coap-client -m get coap://192.168.1.100/dingtian/r7
./coap-client -m get coap://192.168.1.100/dingtian/r8
```

Input Status(1:High, 0:Low)

```
./coap-client -m get coap://192.168.1.100/dingtian/i1
./coap-client -m get coap://192.168.1.100/dingtian/i2
./coap-client -m get coap://192.168.1.100/dingtian/i3
./coap-client -m get coap://192.168.1.100/dingtian/i4
./coap-client -m get coap://192.168.1.100/dingtian/i5
./coap-client -m get coap://192.168.1.100/dingtian/i6
./coap-client -m get coap://192.168.1.100/dingtian/i7
./coap-client -m get coap://192.168.1.100/dingtian/i8
```

## step 3: CoAP Control relay(simple)

```
./coap-client -e "1" -m put coap://192.168.1.100/dingtian/r1 # relay1 ON
./coap-client -e "0" -m put coap://192.168.1.100/dingtian/r1 # relay1 OFF
./coap-client -e "1" -m put coap://192.168.1.100/dingtian/r2 # relay2 ON
./coap-client -e "0" -m put coap://192.168.1.100/dingtian/r2 # relay2 OFF
./coap-client -e "1" -m put coap://192.168.1.100/dingtian/r3 # relay3 ON
./coap-client -e "0" -m put coap://192.168.1.100/dingtian/r3 # relay3 OFF
./coap-client -e "1" -m put coap://192.168.1.100/dingtian/r4 # relay4 ON
./coap-client -e "0" -m put coap://192.168.1.100/dingtian/r4 # relay4 OFF
./coap-client -e "1" -m put coap://192.168.1.100/dingtian/r5 # relay5 ON
./coap-client -e "0" -m put coap://192.168.1.100/dingtian/r5 # relay5 OFF
./coap-client -e "1" -m put coap://192.168.1.100/dingtian/r6 # relay6 ON
./coap-client -e "0" -m put coap://192.168.1.100/dingtian/r6 # relay6 OFF
```

```
./coap-client -e "1" -m put coap://192.168.1.100/dingtian/r7 # relay7 ON
./coap-client -e "0" -m put coap://192.168.1.100/dingtian/r7 # relay7 OFF
./coap-client -e "1" -m put coap://192.168.1.100/dingtian/r8 # relay8 ON
./coap-client -e "0" -m put coap://192.168.1.100/dingtian/r8 # relay8 OFF
```

## step 4: CoAP Control relay

format:

status:type:time:password

status:0,1

type:ON/OFF,DELAY,JOGGING

time:(ON/OFF)0,(DELAY)1~65535second,(JOGGING)1~255\*100ms

password:0~9999

example:

1:ON/OFF:0:4660

status:1

type:ON/OFF

time:0

password:4660

ON/OFF example:

```
./coap-client -e "1:ON/OFF:0:4660" -m put coap://192.168.1.100/dingtian/r1
```

```
./coap-client -e "1:ON/OFF:0:4660" -m put coap://192.168.1.100/dingtian/r2
```

```
./coap-client -e "1:ON/OFF:0:4660" -m put coap://192.168.1.100/dingtian/r3
```

```
./coap-client -e "1:ON/OFF:0:4660" -m put coap://192.168.1.100/dingtian/r4
```

```
./coap-client -e "1:ON/OFF:0:4660" -m put coap://192.168.1.100/dingtian/r5
```

```
./coap-client -e "1:ON/OFF:0:4660" -m put coap://192.168.1.100/dingtian/r6
```

```
./coap-client -e "1:ON/OFF:0:4660" -m put coap://192.168.1.100/dingtian/r7
```

```
./coap-client -e "1:ON/OFF:0:4660" -m put coap://192.168.1.100/dingtian/r8
```

```
./coap-client -e "0:ON/OFF:0:4660" -m put coap://192.168.1.100/dingtian/r1
```

```
./coap-client -e "0:ON/OFF:0:4660" -m put coap://192.168.1.100/dingtian/r2
```

```
./coap-client -e "0:ON/OFF:0:4660" -m put coap://192.168.1.100/dingtian/r3
```

```
./coap-client -e "0:ON/OFF:0:4660" -m put coap://192.168.1.100/dingtian/r4
```

```
./coap-client -e "0:ON/OFF:0:4660" -m put coap://192.168.1.100/dingtian/r5
```

```
./coap-client -e "0:ON/OFF:0:4660" -m put coap://192.168.1.100/dingtian/r6
```

```
./coap-client -e "0:ON/OFF:0:4660" -m put coap://192.168.1.100/dingtian/r7
```

```
./coap-client -e "0:ON/OFF:0:4660" -m put coap://192.168.1.100/dingtian/r8
```

DELAY example:

```
./coap-client -e "1:DELAY:5:4660" -m put coap://192.168.1.100/dingtian/r1
```

```
./coap-client -e "1:DELAY:5:4660" -m put coap://192.168.1.100/dingtian/r2
```

```
./coap-client -e "1:DELAY:5:4660" -m put coap://192.168.1.100/dingtian/r3
```

```
./coap-client -e "1:DELAY:5:4660" -m put coap://192.168.1.100/dingtian/r4
```

```
./coap-client -e "1:DELAY:5:4660" -m put coap://192.168.1.100/dingtian/r5
```

```
./coap-client -e "1:DELAY:5:4660" -m put coap://192.168.1.100/dingtian/r6
./coap-client -e "1:DELAY:5:4660" -m put coap://192.168.1.100/dingtian/r7
./coap-client -e "1:DELAY:5:4660" -m put coap://192.168.1.100/dingtian/r8
./coap-client -e "0:DELAY:5:4660" -m put coap://192.168.1.100/dingtian/r1
./coap-client -e "0:DELAY:5:4660" -m put coap://192.168.1.100/dingtian/r2
./coap-client -e "0:DELAY:5:4660" -m put coap://192.168.1.100/dingtian/r3
./coap-client -e "0:DELAY:5:4660" -m put coap://192.168.1.100/dingtian/r4
./coap-client -e "0:DELAY:5:4660" -m put coap://192.168.1.100/dingtian/r5
./coap-client -e "0:DELAY:5:4660" -m put coap://192.168.1.100/dingtian/r6
./coap-client -e "0:DELAY:5:4660" -m put coap://192.168.1.100/dingtian/r7
./coap-client -e "0:DELAY:5:4660" -m put coap://192.168.1.100/dingtian/r8
```

JOGGING example:

```
./coap-client -e "1:JOGGING:5:4660" -m put coap://192.168.1.100/dingtian/r1
./coap-client -e "1:JOGGING:5:4660" -m put coap://192.168.1.100/dingtian/r2
./coap-client -e "1:JOGGING:5:4660" -m put coap://192.168.1.100/dingtian/r3
./coap-client -e "1:JOGGING:5:4660" -m put coap://192.168.1.100/dingtian/r4
./coap-client -e "1:JOGGING:5:4660" -m put coap://192.168.1.100/dingtian/r5
./coap-client -e "1:JOGGING:5:4660" -m put coap://192.168.1.100/dingtian/r6
./coap-client -e "1:JOGGING:5:4660" -m put coap://192.168.1.100/dingtian/r7
./coap-client -e "1:JOGGING:5:4660" -m put coap://192.168.1.100/dingtian/r8
./coap-client -e "0:JOGGING:5:4660" -m put coap://192.168.1.100/dingtian/r1
./coap-client -e "0:JOGGING:5:4660" -m put coap://192.168.1.100/dingtian/r2
./coap-client -e "0:JOGGING:5:4660" -m put coap://192.168.1.100/dingtian/r3
./coap-client -e "0:JOGGING:5:4660" -m put coap://192.168.1.100/dingtian/r4
./coap-client -e "0:JOGGING:5:4660" -m put coap://192.168.1.100/dingtian/r5
./coap-client -e "0:JOGGING:5:4660" -m put coap://192.168.1.100/dingtian/r6
./coap-client -e "0:JOGGING:5:4660" -m put coap://192.168.1.100/dingtian/r7
./coap-client -e "0:JOGGING:5:4660" -m put coap://192.168.1.100/dingtian/r8
```

# Appendix V How to “input mutual control”

Example param:

DevA IP: 192.168.1.100

DevB IP: 192.168.1.101

web config “Input Control Relay”

“No”:input only control remote output

“Yes”:input control local output and remote output

DevA web config:

Menu

- Setting
- Relay Connect
- Relay CGI Test
- Relay Task
- Input
- Input Link Relay
- IP WatchDog
- Reset User
- To Factory
- Reboot

## Relay

Channel	Protocol	Addr	Baud	Databits	Stopbits	Parity
RS485	Modbus-RTU	1	115200bps	8bit	1bit	None
CAN	Dingtian String	ID	Speed			
		1	125Kbps			
ETH-UDP1	Dingtian Binary	Remote Address	Remote Port	Local Port		
		192.168.1.9	60000	60000		
ETH-UDP2	Input Mutual Control	Other Relay Board IP	Remote Port	Local Port		
		192.168.1.101 DevB IP	60001	60001		
ETH-TCP Server	Modbus-TCP			Local Port		
				502		
ETH-TCP Client	Modbus-RTU Over TCP	Remote Address	Remote Port			
		192.168.1.9	502			
ETH-MQTT	MQTT	Broker Address	Broker Port	Broker Username	Broker Password	
		192.168.1.9	1883	mqtt	123	

**Other**

Relay Password	0	0~9999(0 no password)
Keep Alive Second	30	1~120 second(0 close)
Jogging Time	5	1~255 (1=100ms)
Power Failure Recovery Relay	No	
Input Control Relay	No	DevA input not control relay

**Button Type**

Momentary	Momentary	Momentary	Momentary
-----------	-----------	-----------	-----------

**Save**

DevB web config:

- Menu
  - Setting
  - Relay Connect
  - Relay CGI Test
  - Relay Task
  - Input
  - Input Link Relay
  - IP WatchDog
  - Reset User
  - To Factory
  - Reboot

# Relay

Channel	Protocol	Addr	Baud	Databits	Stopbits	Parity
RS485	Modbus-RTU	1	115200bps	8bit	1bit	None
CAN	Dinglian String	ID	Speed			
		1	125Kbps			
ETH-UDP1	Dinglian Binary	Remote Address	Remote Port	Local Port		
		192.168.1.9	60000	60000		
ETH-UDP2	Input Mutual Control	Other Relay Board IP	Remote Port	Local Port		
		192.168.1.100 DevA IP	60001	60001		
ETH-TCP Server	Modbus-TCP			Local Port		
				502		
ETH-TCP Client	Modbus-RTU Over TCP	Remote Address	Remote Port			
		192.168.1.9	502			
ETH-MQTT	MQTT	Broker Address	Broker Port	Broker Username	Broker Password	
		192.168.1.9	1883	mqtt	123	

Other		
Relay Password	0	0~9999(0 no password)
Keep Alive Second	30	1~120 second(0 close)
Jogging Time	5	1~255 (1=100ms)
Power Failure Recovery Relay	No	
Input Control Relay	No	DevB input not control relay

Button Type			
Momentary	Momentary	Momentary	Momentary

Save

## Relay Test

Relay1:Off    Relay2:Off    Relay3:Off    Relay4:Off

# Appendix VI How to Home Assistant

## Step 1 config Relay board

### Dingtian IOT Relay

## Relay

Channel	Protocol	Addr	Baud	Databits	Stopbits	Parity
RS485	Modbus-RTU	1	115200bps	8bit	1bit	None
CAN	Dingtian String	ID	Speed	Frame Type		
		1	125Kbps	Standard Frame		
UDP1	Dingtian Binary	Remote Address	Remote Port	Local Port		
		192.168.1.9	60000	60000		
UDP2	Dingtian String	Remote Address	Remote Port	Local Port		
		192.168.1.9	60001	60001		
TCP Server	Modbus-TCP			Local Port		
				502		
TCP Client	Modbus-RTU Over TCP	Remote Address	Remote Port			
			502			
MQTT	MQTT	Broker Address	Broker Port	Broker Username	Broker Password	
		192.168.1.9	1883	mqtt	123	

#### Other

Relay Password: 0 (0-9999(0 no password))

Keep Alive Second: 30 (1-120 second(0 close))

Power Failure Recovery Relay: No

**Save**

**Relay Test**

Relay1:Off    Relay2:Off

The "192.168.1.9" is MQTT broker IP

## Step 2 Install MQTT Broker

Link step 1: Install and config Broker for details how to install MQTT Broker

## Step 3 Install Home Assistant

### 1 install python

Python download link:

<https://www.python.org/ftp/python/3.10.0/python-3.10.0.exe>

### 2 install Home Assistant

Windows install command:

```
python -m pip install --upgrade homeassistant tzdata met
```

### 3 Add relay board Switch and input to Home Assistant

Home assistant default config yaml path:

<C:\Users\Administrator\AppData\Roaming\homeassistant\configuration.yaml>

example is 2 channel relay board, SN is 100

when you use it please replace with you relay board SN

SDK path:

MQTT\home\_assistant\_example.yaml

add below lines to [configuration.yaml](#)

```
##### start #####
```

```
switch:
```

```
- platform: mqtt
```

```
  unique_id: dingtian100-r1
```

```
  name: "Dingtian Ethernet Switch1"
```

```
  state_topic: "/dingtian/relay100/out/r1"
```

```
  command_topic: "/dingtian/relay100/in/r1"
```

```
  availability:
```

```
    - topic: "/dingtian/relay100/out/lwt_availability"
```

```
      payload_available: "online"
```

```
      payload_not_available: "offline"
```

```
  payload_on: "ON"
```

```
  payload_off: "OFF"
```

```
  state_on: "ON"
```

```
  state_off: "OFF"
```

```
  optimistic: false
```



qos: 0

retain: false

- platform: mqtt

unique\_id: dingtian100-r2

name: "Dingtian Ethernet Switch2"

state\_topic: "/dingtian/relay100/out/r2"

command\_topic: "/dingtian/relay100/in/r2"

availability:

- topic: "/dingtian/relay100/out/lwt\_availability"

payload\_available: "online"

payload\_not\_available: "offline"

payload\_on: "ON"

payload\_off: "OFF"

state\_on: "ON"

state\_off: "OFF"

optimistic: false

qos: 0

retain: false

binary\_sensor:

- platform: mqtt

unique\_id: dingtian100-i1

name: "Dingtian Ethernet Input1"

state\_topic: "/dingtian/relay100/out/i1"

availability:

- topic: "/dingtian/relay100/out/lwt\_availability"

payload\_available: "online"

payload\_not\_available: "offline"

payload\_on: "ON"

payload\_off: "OFF"

qos: 0

- platform: mqtt

unique\_id: dingtian100-i2

name: "Dingtian Ethernet Input2"

state\_topic: "/dingtian/relay100/out/i2"

availability:

- topic: "/dingtian/relay100/out/lwt\_availability"

payload\_available: "online"

payload\_not\_available: "offline"

payload\_on: "ON"

payload\_off: "OFF"

qos: 0

##### end #####

## 4 Home Assistant config MQTT Broker

Windows open Home Assistant command:

`hass -open-ui`

Home Assistant web link:

<http://127.0.0.1:8123/>

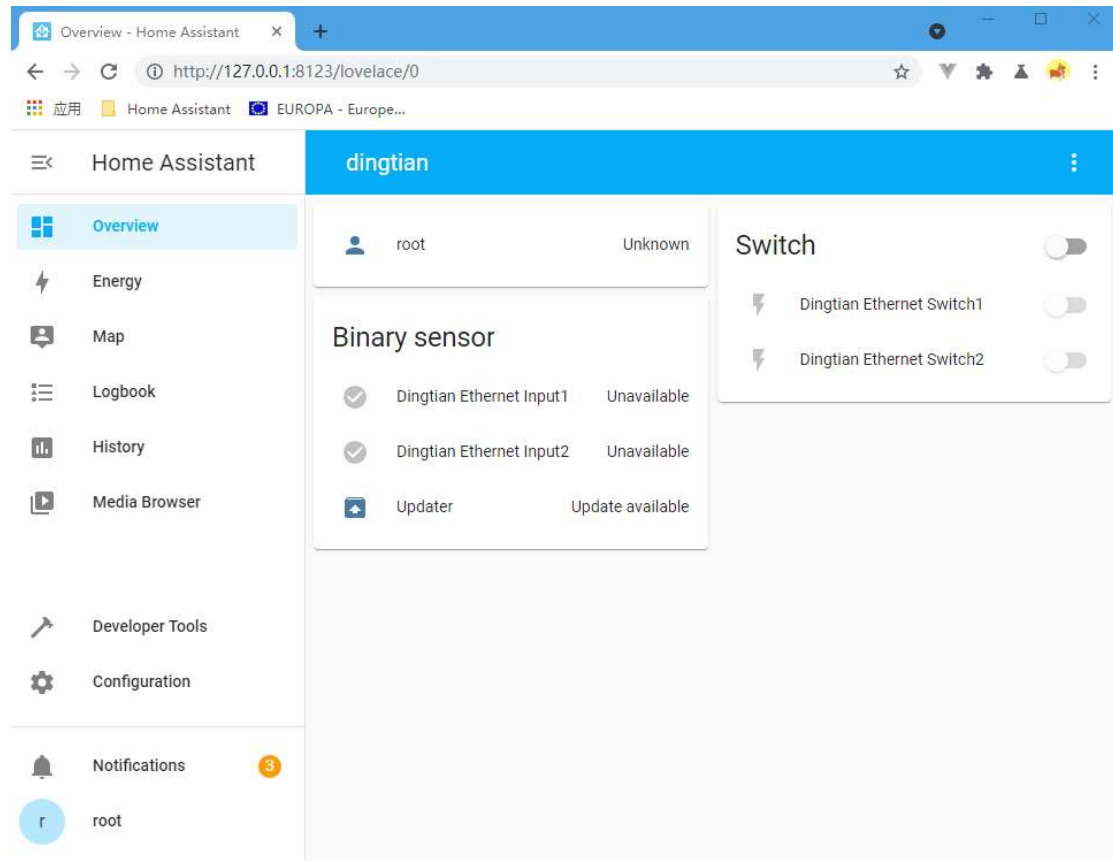

## config MQTT Broker

### step 1

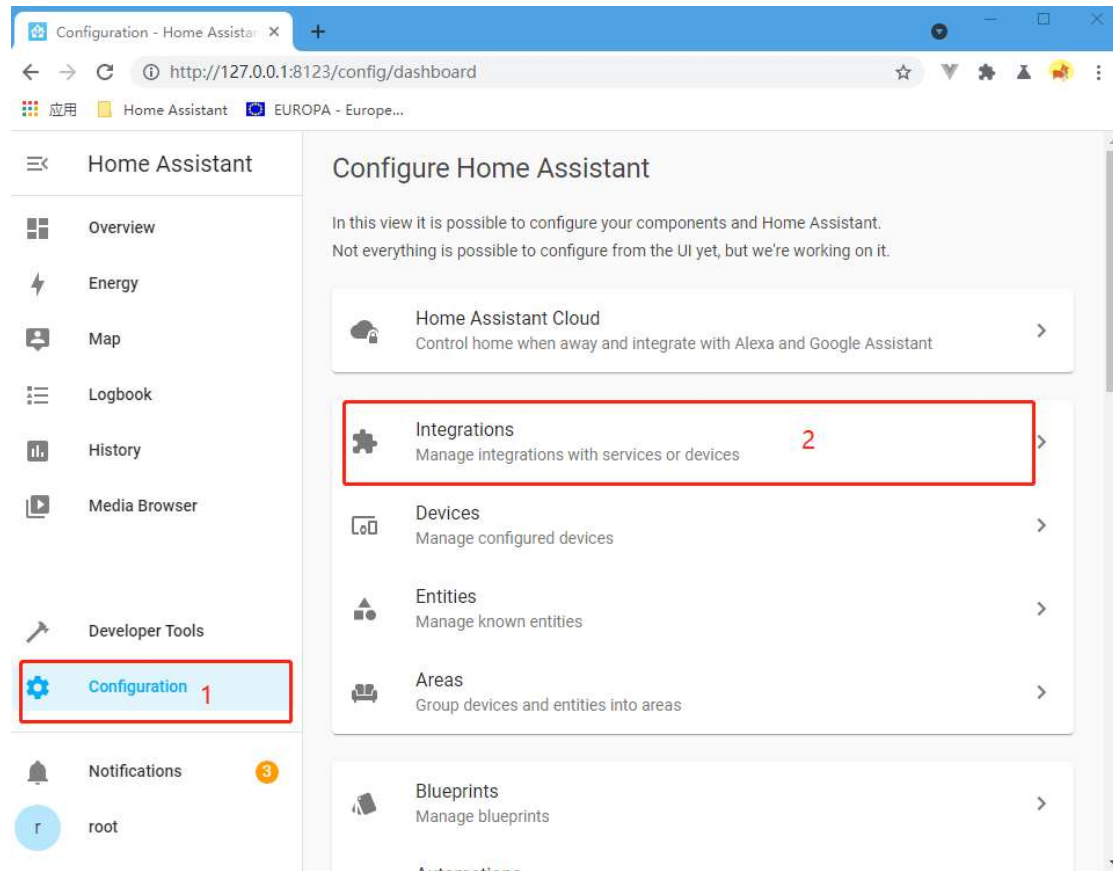

### step 2

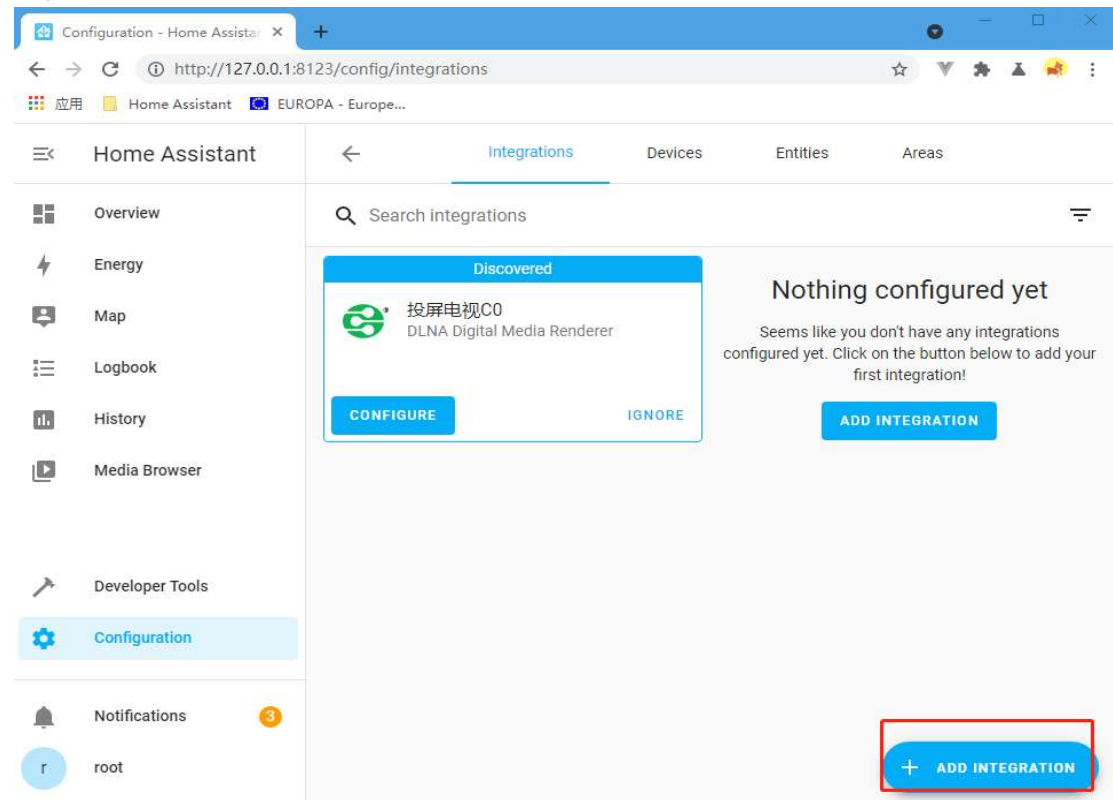

### step 3

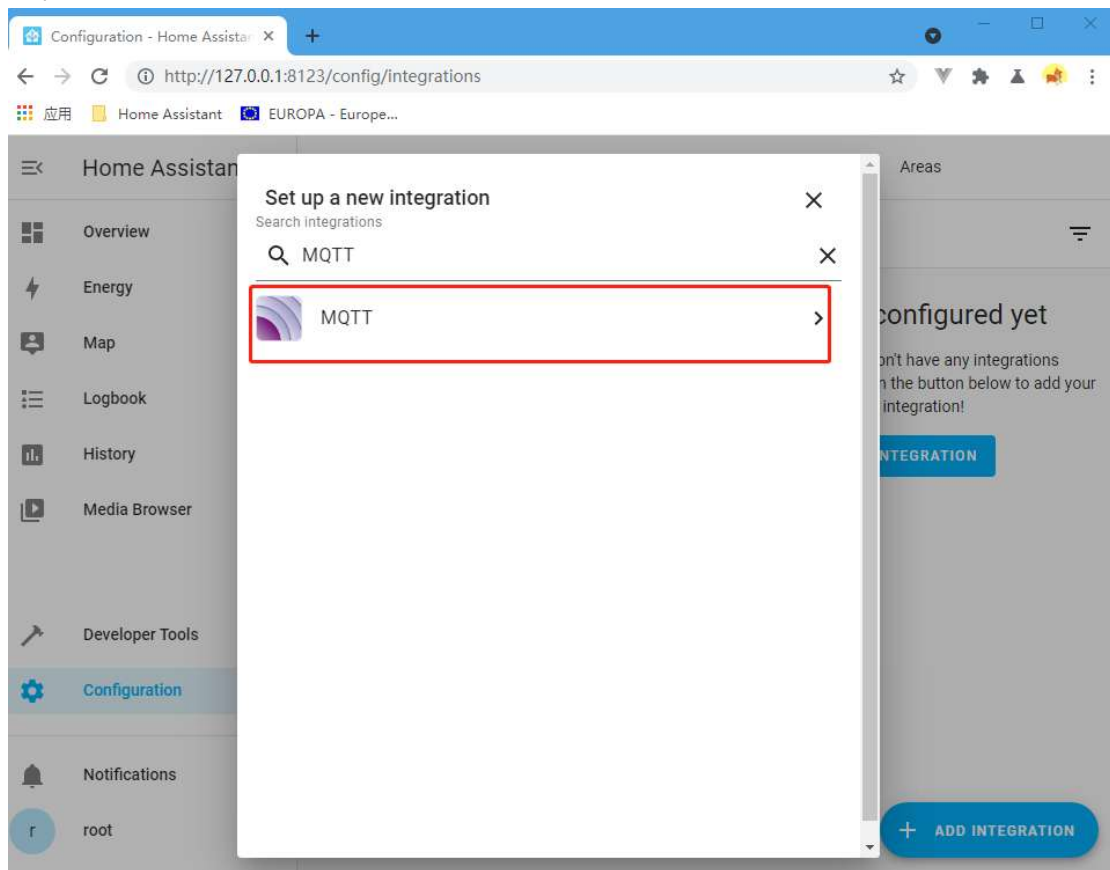

### step 4

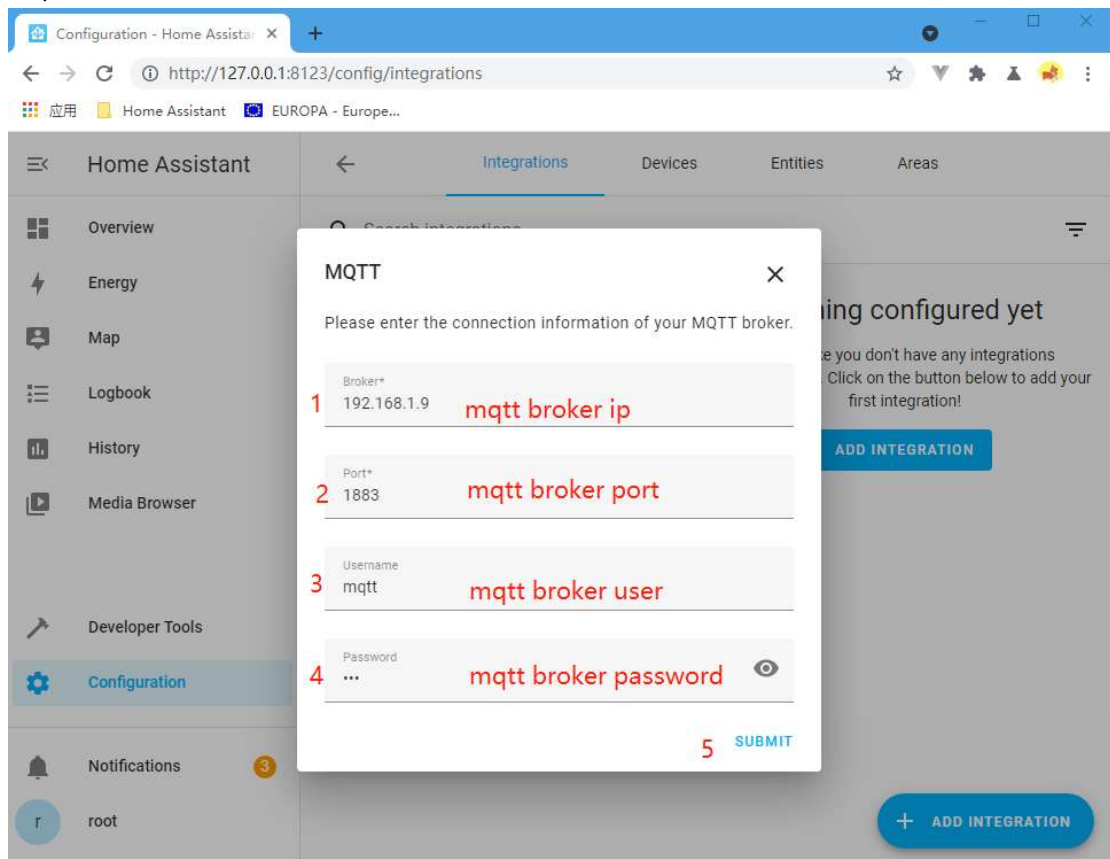

## step 5

The screenshot shows a web browser window with the Home Assistant configuration page. The URL is `http://127.0.0.1:8123/config/mqtt?config_entry=80624d68e8202e0d41077586d6bff11c`. The page title is "Configuration - Home Assistant". The left sidebar shows the "Configuration" menu item selected. The main content area displays the "MQTT options" dialog box. The dialog box contains the following text and options:

**MQTT options** [X]

Discovery - If discovery is enabled (recommended), Home Assistant will automatically discover devices and entities which publish their configuration on the MQTT broker. If discovery is disabled, all configuration must be done manually.

Birth message - The birth message will be sent each time Home Assistant (re)connects to the MQTT broker.

Will message - The will message will be sent each time Home Assistant loses its connection to the broker, both in case of a clean (e.g. Home Assistant shutting down) and in case of an unclean (e.g. Home Assistant crashing or losing its network connection) disconnect.

Enable discovery

Enable birth message

Birth message topic  
homeassistant/status

Birth message payload  
online

Birth message QoS [v]

Birth message retain

Enable will message

Will message topic  
homeassistant/status

Will message payload  
offline

Will message QoS [v]

Will message retain

**SUBMIT**

## step 6

restart Home Assistant

**Ctrl+C** hot key to Stop Home Assistant

**hass -open-ui** to start Home Assistant

step 6

new Home Assistant can control relay and get input status

The screenshot shows the Home Assistant Lovelace interface in a browser window. The browser address bar shows the URL `http://127.0.0.1:8123/lovelace/0`. The interface features a left sidebar with navigation options: Overview (selected), Energy, Map, Logbook, History, and Media Browser. At the bottom of the sidebar are Developer Tools, Configuration, Notifications (with a 2 badge), and a user profile for 'root'. The main content area displays a panel titled 'dingtian' with a user profile for 'root' (Unknown). Below this, there are two sections: 'Binary sensor' and 'Switch'. The 'Binary sensor' section lists 'Dingtian Ethernet Input1' (Off), 'Dingtian Ethernet Input2' (Off), and 'Updater' (Update available). The 'Switch' section lists 'Dingtian Ethernet Switch1' and 'Dingtian Ethernet Switch2', both of which are currently turned off.

Entity Name	Status
root	Unknown
Dingtian Ethernet Input1	Off
Dingtian Ethernet Input2	Off
Updater	Update available
Dingtian Ethernet Switch1	Off
Dingtian Ethernet Switch2	Off